

Foreword



By Barbara Janke
Leader of Bristol City Council

A handwritten signature in black ink that reads "Barbara Janke". The signature is fluid and cursive, with a large loop at the end of the name.

I am delighted to be able to introduce this 2nd edition of Bristol City Council's 'Environmental Access Standards. This revised edition has been authorised to take into account the changes in technical, legal and governmental guidance to promoting Best Practice in environmental design.

These standards are based on the principles of social inclusion which are essential in achieving the highest levels of safe, easy and complete access for everyone, regardless of age, disability or gender. All members of society face barriers to everyday living which can be frustrating but shouldn't result in extreme hardship or complete exclusion. A badly designed or poorly executed built environment can have these results. The needs of all residents and visitors to Bristol should be included in mainstream life if we are to make progress and thrive as a society.

Planning with good guidance is fundamental to the way Bristol looks and works and can positively change the lives of everyone in the in the city. I would intend that Bristol City Council's Environmental Access Standards makes sure that we as a city, can demonstrate the way to ensure equality of opportunity to everyone. It is my real belief that this publication will demonstrate our intention to encourage the highest values in design and alteration of our built and external surroundings and will contribute in a very real way to ending discrimination caused by an unequal environment.

Acknowledgments

The 2006 version of the Bristol City Council Environmental Access Standards is the collaboration between several individuals, organisations and authoritative publications. Bristol City Council would like to acknowledge the support of the many individual contributors and the guidance of organisations and best practice documents in the research and development of this publication.

Bristol City Council thanks:

Wokingham District Council and Swindon Borough Council for the adaptation of elements of their Access Standards publications.

Use of material from organisations such as CIRIA, JMU Partnership and Dept. for Transport and the Disability Rights Commission.

Bristol Physical Access Chain for their advice and opinion on technical and management issues.

Individual departments of the Council whose officers reviewed sections relevant to their areas of expertise. Many of the changes are due to the diligence of these authorities in helping to maintain the high quality of development achieved by Bristol City Council.

Supporting evidence references have been given greater priority than before.

The relevance of these documents and website links has been strengthened by the guidance of the Disability Rights Commission. Their research and publication of Best Practice guidance has supported the development of this document.

Reference is made to the Disability Discrimination Act 1995 though equal direction should be taken from the requirements for Local Authorities within the Disability Discrimination Bill 2005. This council will publish the direction taken later this year with the Council's Disability Equality Scheme.

Contents

Introduction	page 1
Background	3
- What is an Inclusive Environment?	4
- Local Licensing Policies	4
- BS 8300 2001	5
- Planning Policy Guidance Note 1	5
- The Building Regulations	6
- Historic Buildings and Areas	6
- Variation from the Standards	7
Management	8
- Management and Resources	8
- Existing Buildings	9
Point of Arrival	10
- Parking for disabled people	10
- Parking facilities for disabled members of staff	10
Parking Facilities	11
- Enforcement and signage to parking facilities.	11
- Car park entry systems and payment machines	12
- Car Parking	13
- Parking Bays	13
- Car Parking Design and Layout	14
- Drop Kerbs	14
Surfaces	14
- Tactile Paving Surfaces	14
- Positions of Paving	15
- Corduroy Hazard Warning Surface	15
Parking Area	17
- Drop-Off points	17
Access Routes	18
- Approaches and Routes	18
- Dropped kerbs	20
- Ramps and steps	21
External & internal steps	22
- External steps - handrails	23
- Examples of suitable tread nosing profiles	23
Entrances	24
Security	25
Entrance Lobbies	26
Reception areas	27
Doors	29
- Door Closers	30
- Kicking Plates	30

Contents

- Handles	31
- Internal Doors	32
Lobbies	33
Circulation	34
Lifts	35
Escape Routes	38
- Stairlifts with Wheelchair Platform	39
- Vertical Rise Platform Lifts	39
Toilet	40
- Accessible Toilet	40
- Toilet area	42
- Accessible toilet for ambulant Disabled people	44
Signs	45
- Sign specifications	45
- Signage	47
- Positioning of Signs	48
- Counters	49
Equipment	50
- Office equipment	50
- Lighting	50
- Hearing Enhancement Systems	51
- Noise reduction	51
- Induction Loops	51
- Infrared System	52
- FM Radio System	52
- Aids and Equipment	53
- Switches and Controls	54
Open Space	55
- Specification	55
- Surfaces	55
- Clearance	55
- Bridges/boardwalks	55
- Ramps/steps	56
- Pedestrian and Cyclist paths	56
- Barriers and gates	56
- Landscape settings	59
- Signage and wayfindings	60
- Play facilities	60
- Seating and picnic tables	60
Publications	61
Contacts	63
Glossary of Terms	64

Introduction

It is estimated that there are 11.7 million disabled people in the UK. Disabled people have often been denied access to facilities and services that non-disabled people have taken for granted. The difficulties that disabled people have experienced when accessing these facilities and services often relates, not to an individual's disability, but to the lack of thought and lack of awareness of society when designing the built environment around us and when establishing how services are provided. The way that buildings are designed has an impact on disabled people, elderly people and parents with children. Their access requirements should be incorporated into how we shape our world. We can all benefit as accessible design is invariably good for everyone.

A number of pieces of legislation have been introduced in recent years to raise Society's awareness of access issues. The Chronically Sick and Disabled Persons Act 1970, the Town and Country Planning Act 1990, Part M of the Building Regulations revised edition 1999 and the Disability Discrimination Act 1995, are all relevant pieces of legislation that have formed today's approach to designing buildings or assessing service provision.

Bristol City Council is working to ensure that the environment around us is accessible to all. The "Environmental Access Standard" has been produced to give guidance to those who are planning, designing and implementing how we shape the built environment and details the standards of accessibility that the Council will achieve in all development in Bristol City.

In the Integrated Equalities Policy of 1997, Bristol City Council made a commitment to:

- Adopt an access policy covering physical access to buildings, highways, pavements and open spaces.
- Give Disabled people access to information and work to implement this policy.
- Aim to ensure that all of its existing buildings are gradually made accessible to Disabled people.

Introduction

- Plan and implement a rolling programme of access improvements within the timescale of the Disability Discrimination Act.
- No longer purchase any buildings which are inaccessible to Disabled people.

This document establishes a baseline standard for access to buildings, highways, pavements and open spaces with guidance on dimensions, materials and design.

All Bristol City Council new build, building refurbishment or access improvement works should meet this standard. We also recommend the use of the standard as guidance in regeneration projects and by agencies and organisations which are funded, supported or licensed by the council.

Departments will need to consider strategies for making their buildings and spaces accessible in line with this standard, including securing the necessary funding and preparing a rolling programme of improvements.

Background

The government is committed to achieving: "thriving, inclusive and sustainable communities in all regions" – Mission statement, Office of the Deputy Prime Minister, 2003. A fundamental element in achieving this will be the removal of unnecessary physical barriers imposed on people by the poor design and management of buildings and spaces.

Buildings and spaces contribute towards socially inclusive and sustainable communities when their potential users are properly considered as an integral part of their planning, design, service delivery and management.

The Government has produced the following guidance documents, which promote the adoption of an inclusive approach throughout the development process.

- "Planning and Access for Disabled People: A Good Practice Guide". Published in March 2003, by The Office of the Deputy Prime Minister (ODPM). The guide promotes eighteen key points to bring about inclusion through the planning system.
- On May 2004 the new Approved Document Part M, Building Regulations came into effect. Requirement M1 states that reasonable provision shall be made for people to gain access to and use the building and its facilities.
- "Inclusive Projects" explains how to achieve an inclusive environment through the commissioning and procurement process. Published by the Disabled Persons Transport Advisory Committee 2003.

These consistently recommend that the access statement is key to delivering an accessible and useable (Inclusive) built environment.

Background

What is an Inclusive Environment?

The Guide to Inclusive Projects describes Inclusive Environments as:

"... Those that can be used by everyone, regardless of age, gender or disability. This makes them truly functional, efficient and sustainable. If the build quality is also high, then these developments meet the principles of good design. Inclusive environments are made up of many elements such as the attitudes of individuals and society, the design of products and communications, as well as the design of the built environment itself. Inclusive environments recognise and accommodate differences in the way people use the built environment and provide solutions that enable all of us to participate in mainstream activities equally, independently, with choice and with dignity."

An inclusive environment does not attempt to meet every single need but considers people's diversity and breaks down unnecessary barriers and exclusions in a manner that benefits us all. This is significant because although society and individuals have invested heavily in enabling people to manage their personal circumstances effectively (e.g. by providing aids and adaptations for disabled people), many people remain unnecessarily "disabled" by ill-conceived environments." (DPTAC June 2003).

Local Licensing Policies

Many Local Authorities will consider access arrangements as part of their licensing conditions or procedures. It is therefore prudent to ensure that access issues are fully planned for and developed at the beginning of scheme rather than carrying out a retrospective exercise to comply with local licensing conditions.

It is therefore prudent to develop a process that addresses all of the above legislative requirements in a practical and consistent manner.

BS 8300 2001: Design of buildings and their approaches to meet the needs of disabled people – Code of practice

The BSI has published a new code of practice on accessible design to explain how the built environment can be designed to anticipate, and overcome, restrictions relating to access that many disabled people encounter. The document covers a wide range of impairment related situations and different types of buildings including homes, retail, employment, sports venues and theatres.

The British Standard is a source of best practice for architects, builders, and facilities managers and encourages innovative design solutions. Reference should be made to this comprehensive Standards source, in addition to this publication.

Planning Policy Guidance Note 1 (PPG1)

Most recent Government advice for planning authorities appeared in the form of PPS 1. This states that:

"Proposals for the development of land provide the opportunity to secure a more accessible environment for everyone, including wheelchair users, other people with disabilities, elderly people and those with young children. Local planning authorities, both in development plans and in determining individual planning applications, should take into account access issues. These will include access to and into buildings, and the need for accessible housing. The internal layout of buildings is not normally material to the consideration of planning permission. Part M of Schedule 1 to the Building Regulations 1991 imposes requirements on how non-domestic buildings should be designed and constructed to secure specific objectives for people with disabilities. It would be inappropriate to use planning legislation to impose separate requirements in these areas....."

When a new building is proposed, or when planning permission is required for the alteration or change of use of an existing building, the developer and local planning authority should consider the needs of people with disabilities at an early stage in the design process.

Background

They should be flexible and imaginative in seeking solutions, taking account of the particular circumstance of each case.

Resolving problems by negotiation will always be preferable, but where appropriate the planning authority may impose conditions requiring access provisions for people with disabilities. Such conditions should fulfill the tests set out in Circular 11/95."

Most planning practitioners should also be conversant with the good practice guide "Diversity and Equality in Planning" ODPM Jan. 2005. This booklet describes and exemplifies how planning teams may encourage inclusive design on relevant applications.

The Building Regulations

Part M of the Building Regulations 2004, "Access to and use of buildings", requires reasonable provision for disabled people be made to all new dwellings, public buildings and extensions. The design guidance detailed in this document sets out standards of accessibility that in some places goes beyond minimum standards detailed in the Building Regulations for achieving reasonable provision.

Historic Buildings and Areas

Bristol has a number of Listed Buildings and Conservation Areas which provide a rich and varied heritage which is important to protect and enhance. This should not be seen as an obstacle to providing a more accessible environment, though often more innovative solutions will be required to ensure that the character of such buildings and areas is respected. Bristol's Development Plan Policy on conservation and listed buildings, will indicate the approach intended by this authority. Difficulties can invariably be overcome with thought, quality materials and informed design advice. Anyone interested in improving access within a conservation area or in a listed building should consult the local authority in question who will be able to provide further advice.

Further advice can also be found in English Heritage's guidance document entitled "Improving Access for Disabled People to Historic Premises". This helpful document details good practice when considering improving access on historic sites.

Variation from the Standards

Appropriate solutions to access barriers may vary according to the size, nature and intended use of the building or site. Where it is felt the standards cannot be met as suggested in this document, an Access Statement should be developed which will identify the philosophy and approach to inclusive design taken. Access Statements should be developed after liaison with:

- The Strategic Access Officer
- Local access groups
- Local disability organisations
- Relevant council officers

In all instances the client should be conversant with related guidance documents, e.g. BCC Standards, Building Regs. Part M, BS8300. The Statement should offer convincing argument that an alternative solution will achieve the same or better solutions to access difficulties. The Statement should set out the reasons for departing from the guidance and why the solutions offered will meet the needs of disabled people as much as is reasonably possible. The Statement should clearly set out most of the information needed to answer queries by the relevant authority e.g. Access Officer, Building Control, Planning and Conservation and English Heritage. It may be beneficial to maintain and update the Statement in order to provide the end user with a document indicating the rationale for decisions taken. The information contained in the Statement would be capable of forming the basis of a site-specific building (or site) operation and maintenance handbook.

Management

Management and Resources

Good management of a building is the key to providing and maintaining the accessibility of services and employment within any building. A well designed building or environment can be made impossible or difficult to use if management and maintenance practices ignore access issues. A good management programme should be inclusive in both process and practice. The programme should form an Inclusion Loop such as the one in Diagram (A)

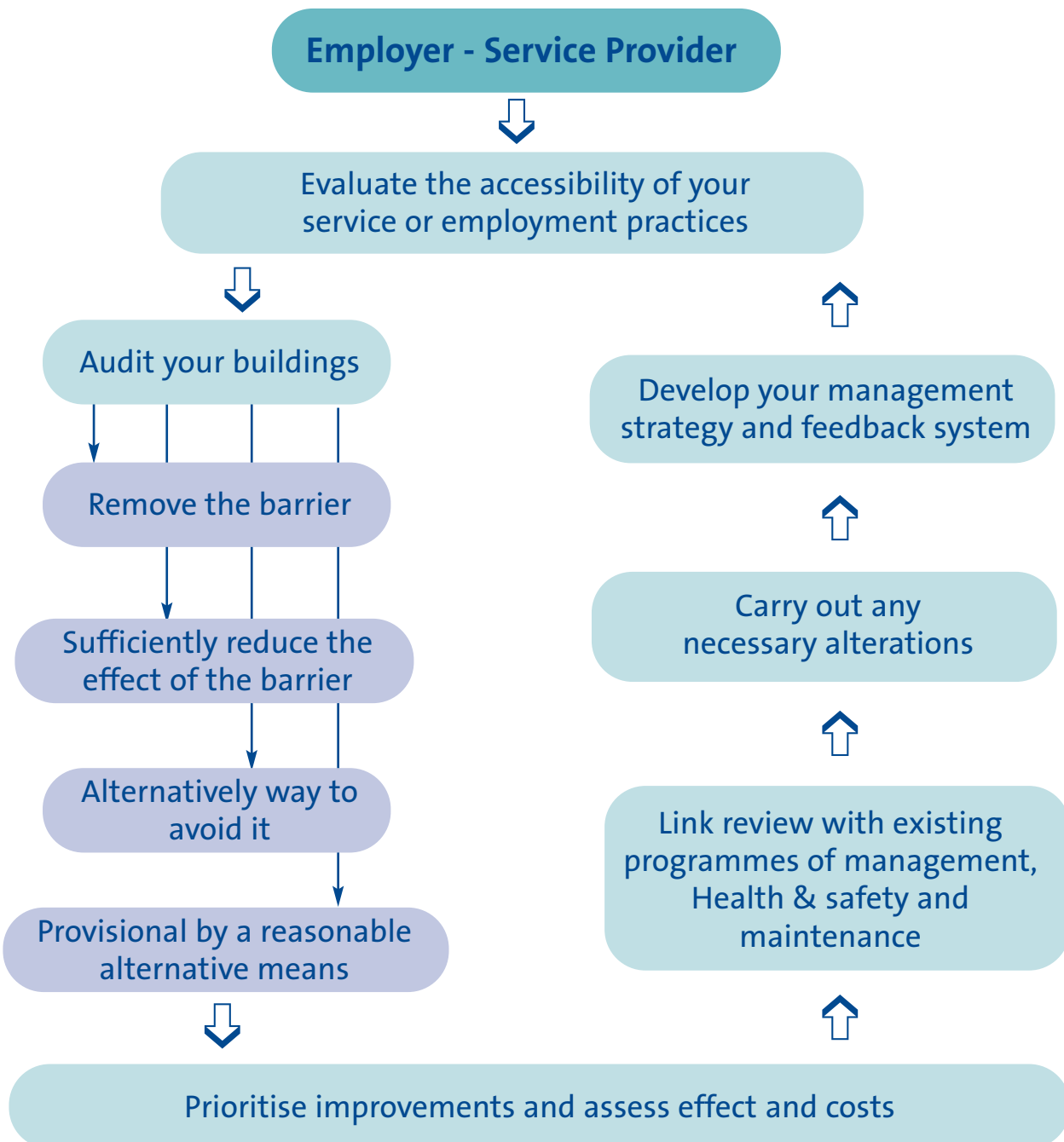

Diagram (A)

Existing Buildings – Opportunities for improvements

There are many opportunities throughout the life of a building to make improvements for accessibility. In using the chance to make changes, costs are often reduced and interruptions are lessened. Use of the maintenance schedule to redecorate in a better contrasting colour scheme for example, would have no additional cost implications. In the periodic refurbishment programme replace worn out fittings, floor coverings, door and window fixtures and other elements to introduce suitable equipment and fabrics, which are better suited to meeting the needs of everyone. Work done to meet Fire and Health & Safety requirements, might allow better signage, remove obstructions and upgrade taps, door furniture, lights and other fittings.

If some barriers are unavoidable, employers and service providers must ensure that their staff are aware of any shortcomings and can make the public aware of these. It is only sensible (and a legal requirement) to make sure that information in printed leaflets, email or over the phone do not mislead a disabled person about the accessibility of premises or services. It may be that a guide to access is produced for a building or group of buildings providing a particular service. All such information should be readily available in alternative formats such as large print, audiotape or computer disc.

Staff training is therefore essential to manage the process of ongoing change in relation to the DDA 1995. Well-trained staff can make a very positive contribution to the way in which everyone uses a building. Staff appraisals should include knowledge of access for disabled customers both of the services and the buildings from which they deliver them.

Point of Arrival

Parking for disabled people

The number of disabled persons' parking bays that should be provided will depend on the type of building.

The above guidance is considered best practice and is taken from BS 8300.

Type	Provision	Provision for Visitors
Workplaces (number of employees known)	One bay for each employee who is a disabled motorist	1 space or 2% of total capacity (whichever is the greater)
Workplaces (number of employees unknown)	One bay for each employee who is a disabled motorist	1 space or 2% of total capacity (whichever is the greater)
Shopping Recreation and Leisure	One bay for each employee who is a disabled motorist	6% of total capacity
Railway car parks	One bay for each employee who is a disabled motorist	5% of total capacity
Churches	One bay for each employee who is a disabled motorist	At least 2 spaces

Parking facilities for disabled members of staff.

Disabled persons parking bays should also be provided for staff and be located nearest to the staff entrance (if different from the main entrance). If you have an employee with a disability who uses a car, discuss where the most appropriate location for a bay would be for them.



Parking Facilities

Ambulant disabled user-only where space is limited. Full width for wheelchair user is preferred particularly in public parks

Full width to suit wheelchair user is preferred

Marked out shared space between two standard bays

Standard bay but with outer side safeguarded for access

Flush kerb edge

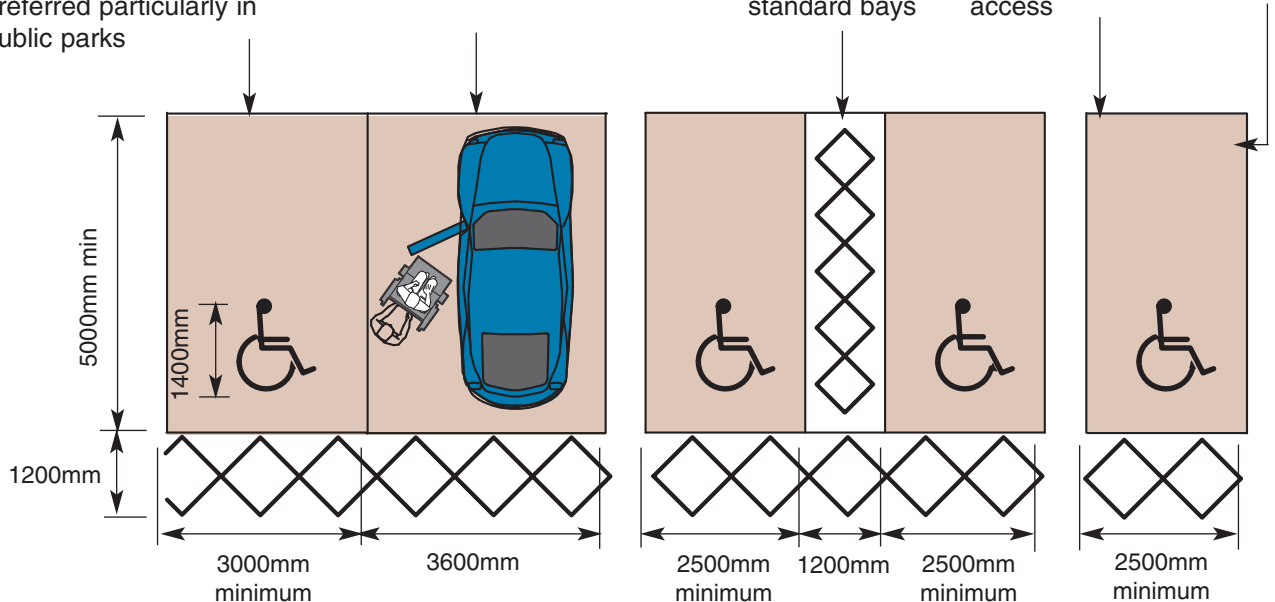

Enforcement and signage to parking facilities.

Signs play an important part in trying to stop the misuse of disabled persons parking bays. Signs on the highway come under Department for Transport regulations. However, private car parks are not covered by these regulations. It is suggested that most disabled people who have access to a car will participate in the national Blue Badge Parking Scheme, formerly Orange Badge scheme.

The Blue Badge Parking Scheme is a national scheme for people with limited mobility. The badge is allocated to individuals and not to vehicles. Signage should refer to Blue Badge holders, ensuring that the parking bays nearest the entrance are clearly designated for people with limited mobility. Signs in larger car parks may be necessary to direct drivers to the disabled persons' parking bays.

Disabled persons parking bays are prone to misuse by some inconsiderate drivers. This will continue if disabled persons parking bays are not monitored and enforced by car park management. Building managers should consider effective ways to stop misuse. If a disabled person cannot park near to a facility

Parking Facilities

then there is often little option but to turn round and go somewhere else where they can park with ease. You may be losing customers and employees by failing to enforce your disabled persons' parking bays. There may also be implications for your organisation under the Disability Discrimination Act (1995).

Car park entry systems and payment machines

Many car parks have automated entry systems and payment machines. Such equipment may be difficult for some disabled people to use unless thought is given to the design and installation.

Pedestrian payment machines should be installed so that touch buttons, ticket and coin slots and intercom panels are located between 1000mm and 1200 high.

Payment machines should not be located on plinths, giving little thought to access for wheelchair users, people of small stature or those with limited arm reach.

An unobstructed area of 1500mm square should be provided immediately in front of the payment machine with adequate dropped kerbs provided on approach routes. Entrance and exit ticket systems should be able to accommodate the larger adapted vehicles often used by disabled people and community transport operators. Car park height restrictions can additionally affect access to parking areas for such users – alternative parking for these vehicles should be provided if this is unavoidable.

Consideration should also be given to the design of intercom systems, which some deaf people can find difficult to use. Therefore, their installation should be avoided unless accompanied by visual text displays or visual indications that the request for assistance has been acknowledged and that the nature of the caller's business is now being asked.

Car Parking

- Locate car parking as close as possible to the accessible entrance.
- Maximum distance of 40m to principal entrance with a level route.
- Parking must be provided on flat ground with a crossfall of not more than 1:50 (in one direction only)
- Drop kerbs to be provided for access to footpath.
- Where possible provide covered drop-off close to main entrance.

Parking Bays

- Kerb side bays must be provided to buildings where dedicated spaces cannot be provided.
- To be located where possible where they can be viewed from the building they serve.
- Fewer than 20 spaces, a minimum of 1 reserved space 20 to 60 spaces, a minimum of 2 reserved spaces 61 to 200 spaces, 6% of capacity, with a minimum of 3 reserved spaces. Over 200 spaces, 4% of capacity, plus 4 reserved spaces.
- An additional space should also be provided for any employee who is a disabled motorist.
- Car parks must be well lit to BS 5489 100 LUX minimum in external areas.
- Site Managers must ensure that designated bays are kept clear for disabled people.
- A sign must be provided at each entrance and at each change of direction to direct disabled motorist to designated parking bays.
- Signs must be positioned at a height that renders the sign obvious.
- Ensure that signs can not be obscured by intervening objects eg: parked vehicles, over hanging trees.

Parking Facilities

Car Parking Design and Layout

- Space must be provided to enable a disabled motorist or passenger to alight from a vehicle and then manoeuvre around parked vehicles.
- Routes to and from these spaces should be clearly indicated and as near to the entrance to any building as possible.

Drop Kerbs

Follow the guidance on tactile paving and use of dropped kerbs given in the Department for Transport Guidance on the use of Tactile Paving 1997.

- All car parks using raised footways should incorporate dropped kerb access at a point appropriate to pedestrian access, i.e. not blocked by the parked vehicle or other obstructions.

Tactile Paving Surfaces

Blister Surface for Pedestrians

Colours

- Red blister surfaces must not be used at any location either than at controlled crossings
- Buff or other colours are to be used to provide colour contrast with the surrounding surfaces.

Size

Slab Type	Slab Size mm	Pitch Dimensions mm	
		A	B
A	400 sq	66.8	33
B	450 sq	64	33
C	200 x 133	67	33

Positions of Paving

Tactile paving must be used at the following locations:-

- Where a footway/path has been dropped level with the carriageway
- Where the footway/path has been raised to the level of the footway
- Where the back edge is not parallel to the kerb, and as a result the depth of the tactile surface varies, it should be no less than 800mm at any point.
- Tactile surface must be installed to a depth of 1200mm across the full width of the flush dropped kerb, where the drop kerbs are directly opposite at junctions.
- Where the in-line crossing is not at a junction then the tactile surface is to a depth of 800mm.
- Where there is no in-line drop kerb then the tiles must be to a depth of 400mm

Corduroy Hazard Warning Surface

Colour

The colour of the corduroy warning surface should be buff or other colour to contrast with the surrounding surface.

Red slab must not be used as this colour is restricted to use at controlled crossings.

Location

Corduroy surface must be used for any situation (except road crossing) where visually impaired people need to be warned of hazard and advised to proceed with caution, eg:-

- top and bottom of steps
- a level crossing
- where a footway/path joins a shared route

Surfaces

- The foot of a ramp to an on-street light transit (LTR) platform, but not at any other ramp

Corduroy surface must not be used to warn of obstacles, where people should be advised not to proceed, eg bike stands, street furniture .

Size

Slabs can be either 400mm x 400mm or 200 x 133mm with raised ribs of 6+ 0.5mm to a width of 20mm.

Further information can be obtained from Guidance on use of Tactile Paving Surface published by DETR (Department of Environment, Transport & Regions).



Drop-off points

Drop-off points are useful for people arriving by taxi or minibus. Lay-bys allow a person to take their time when getting out of a vehicle, vehicles blocking routes can put pressure on disabled people to be as quick as possible which can be stressful. Consider covered drop-off points where possible.

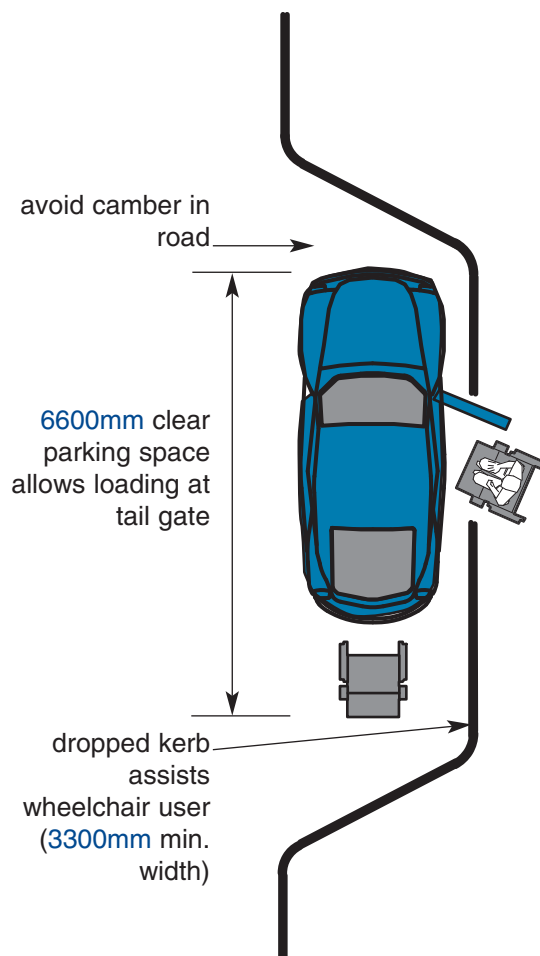

Guidance on pedestrian environment layout can be more fully understood with references to 'Inclusive Mobility: A guide to Best Practice of Access to the Pedestrian and Transport Infrastructure, ODPM 2002'

Approach Routes

Approaches and Routes

All access routes from the boundary and from any car parking designated for disabled use to the principal entrance should be level. All surfaces must be non-slip and have an even surface.

If level routes cannot be achieved to the principal entrance or to an alternative commonly used accessible entrance, the gradient must be no steeper than 1:20 along its whole length.

All routes should be at least 1800mm in width. Any necessary width reductions for obstructions should be to an absolute minimum of 1000mm for not more than 6000mm.

Drainage channels and gratings should if possible be positioned beyond the boundary edge of all access routes. Where drainage gratings are used they must have slots of no more than 13mm wide and run at right angles to the line of travel. Any other style of gratings should have holed openings of no more than 18mm diameter.

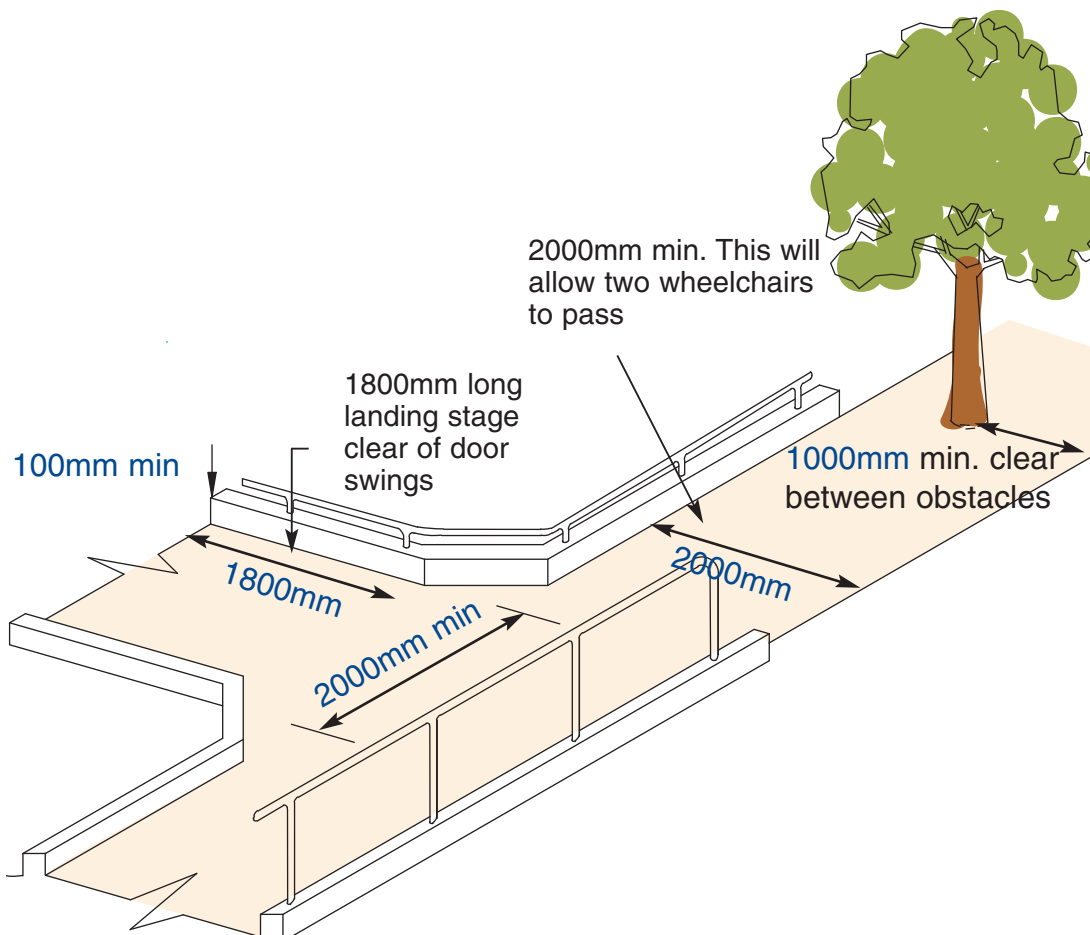

Approach Routes



All efforts should be made to restrict necessary clutter to a minimum along the line of expected travel. Street furniture i.e. lighting columns, litter bins, seating and signposts should be located at or beyond the boundary edge of the footway.

Consideration should be given to highlighting the presence of obstacles such as cycle racks by a tactile and colour change. Use of ribbed paving around likely projections should enhance warning of their presence.

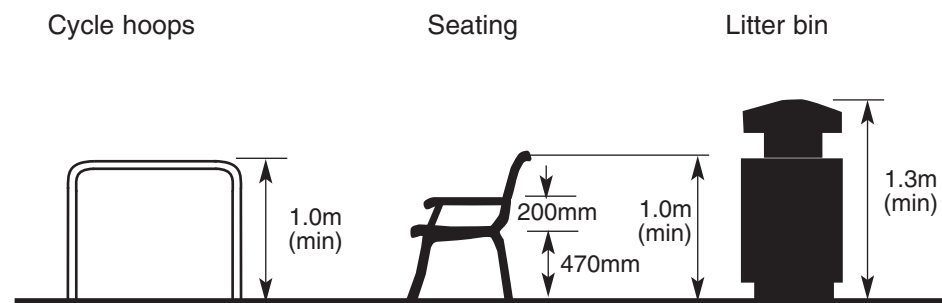

Footway obstacles

Lighting levels to all routes must comply with BS5489 – Part 3.

Signage should be provided in accordance with Best Practice guidance, along routes to aid wayfinding.

Where the natural ground level is below the side of a route or ramp precautions must be taken to prevent tripping or slip hazards. Consideration should be given to reduction of the fall away, use of handrails or kerb upstands or suitable barrier planting.

All routes must have a crossfall gradient of not more than 1:50 except when associated with a dropped kerb.

Approach Routes

Dropped kerbs

Many disabled people as well as older people and parents with pushchairs benefit from the installation of dropped kerbs. Dropped kerbs should be provided on all approach routes to a building whether from parking bays, drop-off points, bus stops or from the perimeter of the site.

Dropped kerbs should be flush and maintained as flush; the smallest upstand can create a potential tripping hazard or jolt a person in a wheelchair. Tactile paving should be installed where a kerb has been dropped and is flush with the carriageway. Tactile paving is installed to warn blind and partially sighted people to proceed with care as a kerb edge no longer defines footway and carriageway.

Tactile paving should be installed in differing ways dependant on the location and the information you wish to give a blind or partially sighted person. The Department for Transport (DfT) issued detailed guidance on the use of tactile paving; this guidance should be followed in consultation with the Council's Highways Team.

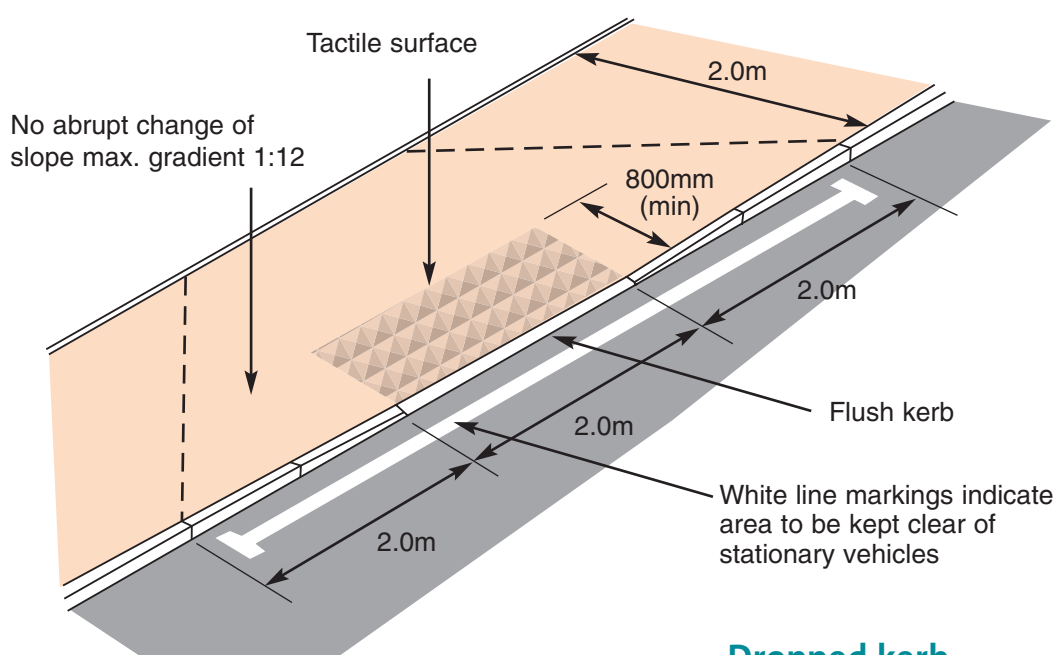

Dropped kerb

Approach Routes

Ramps and steps

Handrails should be provided on both sides of a ramp more than 2000mm in length at a height of at least 900mm and no more than 1000mm, extending 450mm past the top and bottom landings, unless this causes a Health & Safety problem.

Handrails that are too large or small in diameter will be difficult to grip and it is therefore recommended that the diameter of a handrail be between 40mm and 50mm. Handrails should contrast in colour to their surroundings to assist partially sighted people to locate the handrail. A secondary handrail at 600mm must be fitted in Primary schools or other locations used by young children.

Ramps are often designed to these minimum standards and yet a ramped approach should be equal in status to a stepped approach. Experience has shown that non-disabled people as well as disabled people will take the most direct route from A to B, if the most direct route is the ramped access then the ramp will be heavily used and 1500mm will be not be sufficient width. Therefore minimum standards should be exceeded wherever possible.

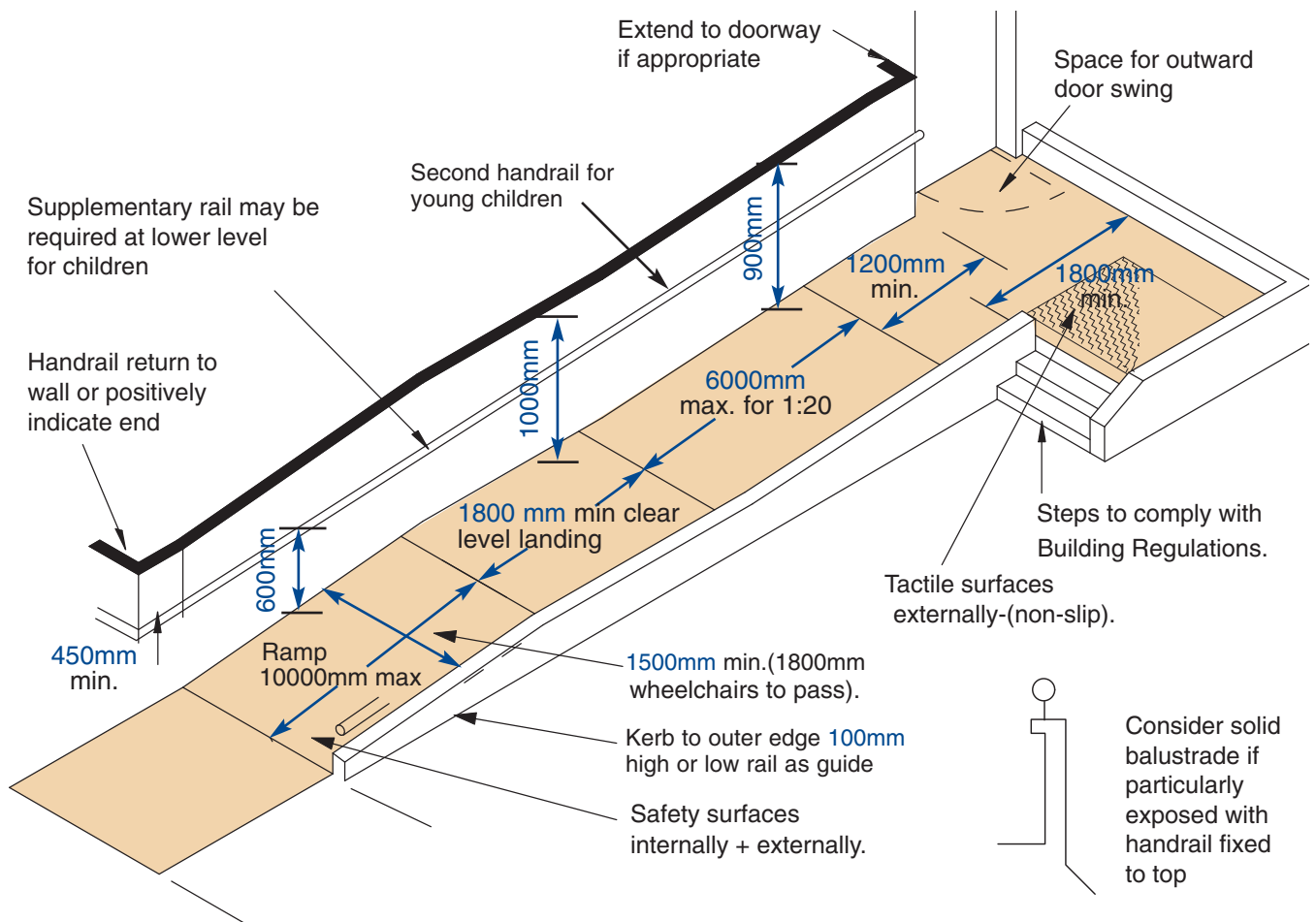

External & internal steps

External & internal steps

- Handrail on both sides 40/50mm diameter continuous across landings, and distinguished from background (eg by colour contrasting). Handrails to be provided for all steps no matter how few.
- Unobstructed width of stairs 1200mm.
- Return handrail to wall: rail should not project into route of travel.
- Open risers not permitted.
- Visual and tactile indications of floor level on landings on external stairs.
- All nosings distinguished by contrasting colour. 30mm band on going and riser. Nosing 15mm maximum beyond riser face.
- Intermediate landings - width and depth at least equal to width of flight.
- Landings shall be clear of any door in the open position.
- Intermediate landings shall be middle of stairs and 1200mm deep, 1200mm minimum width and clear of any door swings.
- Internal ramps 1:20 maximum.
- Ramps and steps should be lit to 150 lux minimum.
- When second handrail fitted for young children handrails, must be as one above the other, not off set.

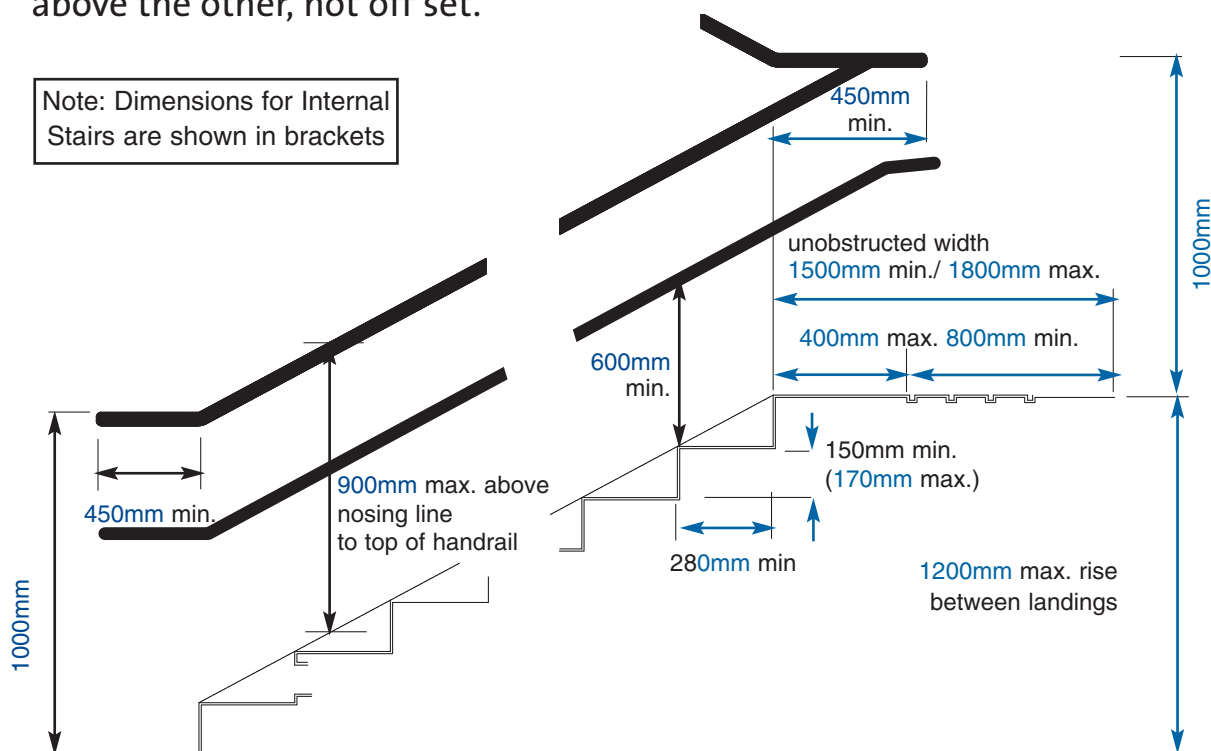

External & internal steps

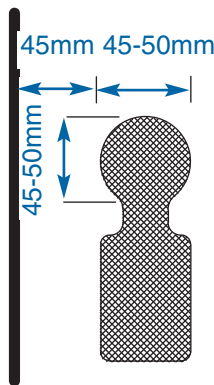
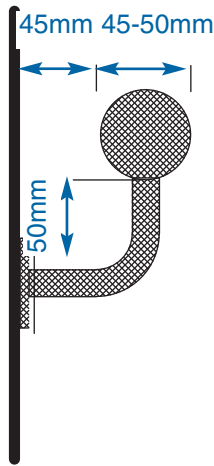

External steps - handrails

- Handrails should be contrasted by colour/and/or tone from their surroundings.
- Handrails should offer adequate grip and support, be continuous and extend across landings.
- Consider solid balustrade where particularly exposed.
- The width of the stairs between handrails should be at least 1200mm.
- An additional rail to be provided at 600mm for children.
- Handrails should be positioned at 900 mm above the ramp or pitch line of stairs and 1000mm above the landing stage.
- Handrails materials should be chosen to avoid temperature extremes.

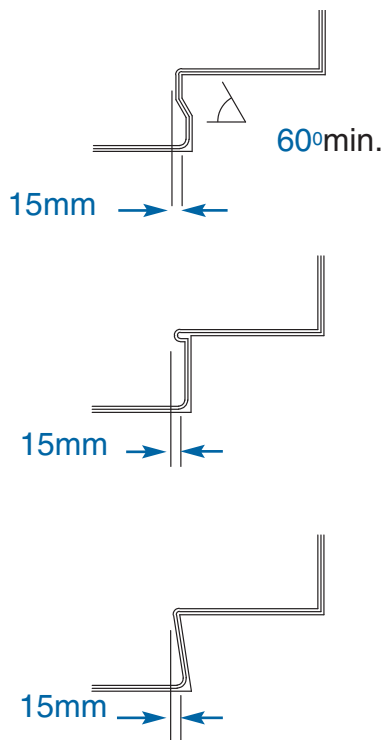

Examples of suitable tread nosing profiles

- Profiles should assist people with a mobility impairment.



Entrances

Entrances

- 1140mm wide doorset modules on 1000mm door opening.
- Ensure doors are placed in logical relationship with routes and easily distinguishable from facade with good signage and external lighting.
- Door furniture should be of a lever handle type, warm to the touch and contrast in colour and luminance with the door surface.
- Any double door set must ensure that the leading door has a 1000mm clear opening width.
- Fully glazed doors are not recommended.
- Existing fully glazed doors to have 3 x 150mm wide contrasting safety/bands at skirting level, then between 850-1000mm and 1400-1500mm.
- Exit Only Doors - should have a clear opening width as well as flush thresholds and external ramps.
- Revolving Doors - should not be used.
- Automatic Doors - Sliding automatic doors are recommended. Define approach and provide tactile and visual information. Ensure doors are distinguishable.
- Thresholds - flush thresholds essential.

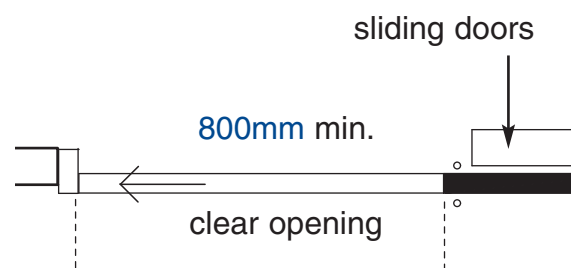
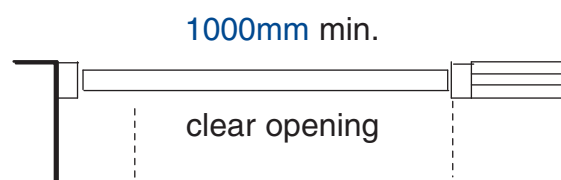
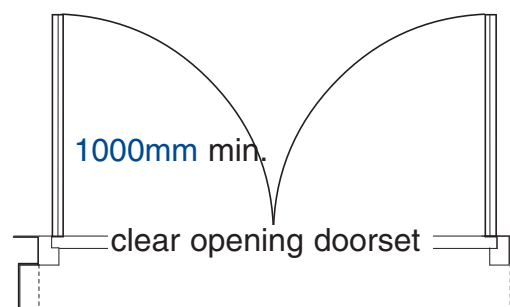
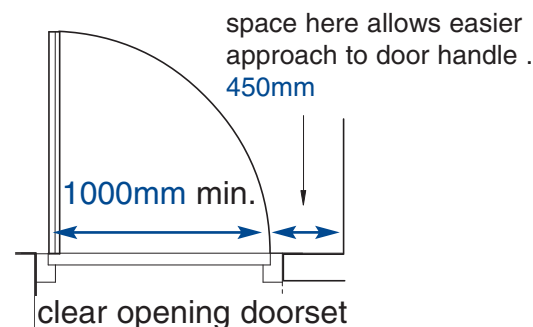

Security

- Only use entryphone / door entry systems where essential.
- Ensure that entry systems and door release buttons are accessible by wheelchair users, on opening side of door and no higher than 900mm.
- Should be located on the latch side of the door with the activation unit within 200mm of the doorframe.
- System should incorporate an LED or similar lighted signal for the benefit of hearing impaired people.
- All systems should have a camera or viewer units placed at convenient heights for all intended users.
- Use hands free models where possible.
- Provide clear signs and instructions for use. Signs to instruct deaf people in their operation should be included.
- Avoid using digilocks.
- Ensure that main entrances are open to allow egress for members of the public for at least 15 minutes after building closes.
- Early consultation with staff and building users will assist in determining the preferential entry system.
- Consideration should also be given to fire exit door requirements - automatic systems should revert to the open position in emergencies.



Lobbies

Entrance Lobbies

- Lobbies should be avoided as these cause difficulties to disabled people with a mobility impairment. Use automatic doors where possible.
- Spaces shown are adequate to allow a wheelchair user to manoeuvre and to clear one set of doors before negotiating the next.
- Dimensions shown are minimum. Thresholds should be flush at both doorsets. Matwells should be flush including surrounds, close fitting, even and non-slip.
- Door opening widths should apply to inner and outer doors. Transitional lighting to reduce contrast between outside and building interior is necessary.

Avoid positioning doors at 90° to one another (as in fig. a)

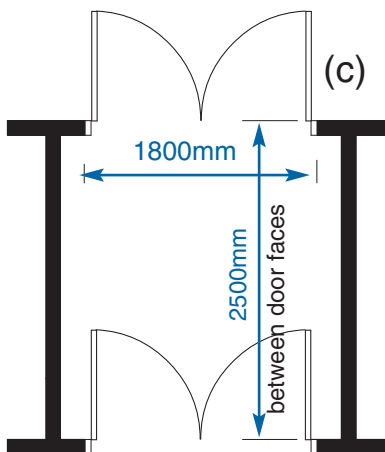
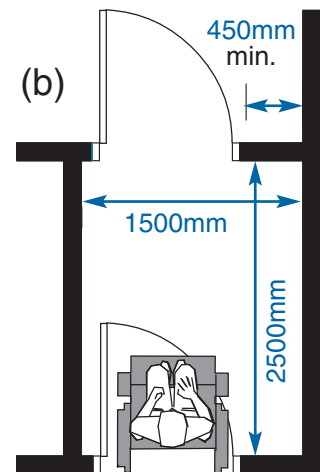
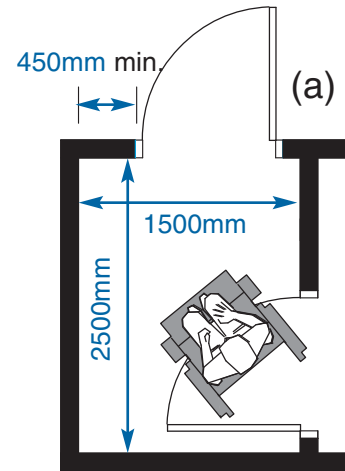

2500mm Automatic hinged doors
2100mm. Sliding doors

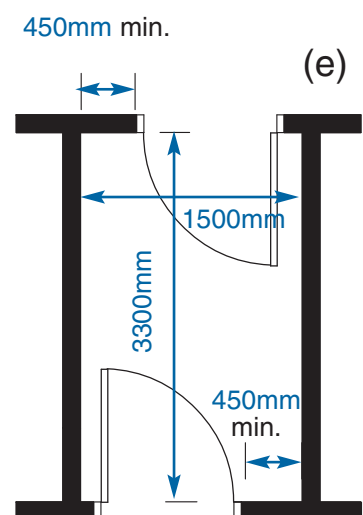
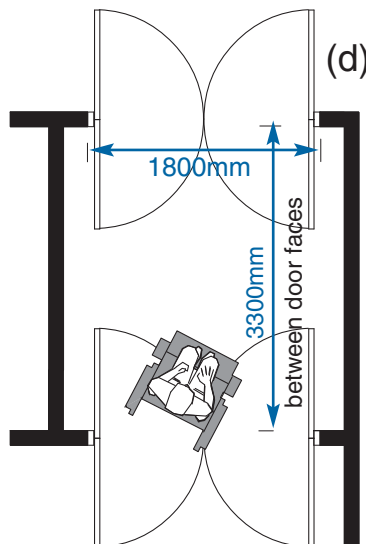

Receptions

- Clear view in from outside is important.
- Reception/waiting area should be quiet and well lit.
- Seating of varying heights should be provided. Some seating with arms would be useful.
- Reception areas should be in sight of the entrance and easily identifiable by visually impaired people
- Must be located in a position where the ability of a person to lip read is not impaired, eg. in front of a window or a glazed screen.
- Counters should not be placed in front of patterned background.
- Good colour contrast should be maintained.
- Reception and waiting areas should be well lit.
- Seating of varying types and heights should be provided with space for wheelchair along side seating.
- Provide a loop system or similar at counter.
- All counter or reception desk should be capable of being staffed by wheelchair users.
- See design details in BS8300 clause.
- Should have a working surface height at two heights.
 - a) between 950-1100mm for people who are standing.
 - b) 760mm to accommodate wheelchair users.
- The desirable length of a low level counter or reception desk work surface should be 1800mm.
- The depth of work surface where a customer and receptionist are opposite each other, where one is in a wheelchair, there must be a 700mm minimum.
- Where the reception/counter is involved in the transaction of tickets or coins the work surface must have an upward sloping leading edge,
- All reception desks must have an induction loop system conforming to BS 6083.
- Where there is the possibility of excess background noise, alternative communication aids (headset and VDUs should be made available.

Doors

- All doors which are across circulation routes or where the opening action could constitute a hazard must have a visibility zone (window).
- This zone is to be 400mm wide minimum and have minimum dimensions of 600 to 1500mm above finished floor level.
- Ideally this zone should be towards the leading edge of the door although this may be limited by the door furniture required.
- To aid identification of doors, architrave must contrast in colour with luminance with wall surfaces surrounding the doorway and the door itself.
- Any door that is likely to be held open must have the leading edge contrast in colour/luminance with remaining surfaces of the door and its surroundings.
- All new timber doors must have low level protection by fitting of 400mm high kicking plate.
- All internal doors must provide a minimum 900mm clear opening, with 450mm minimum space along side leading edge to allow easier approach to door handle.

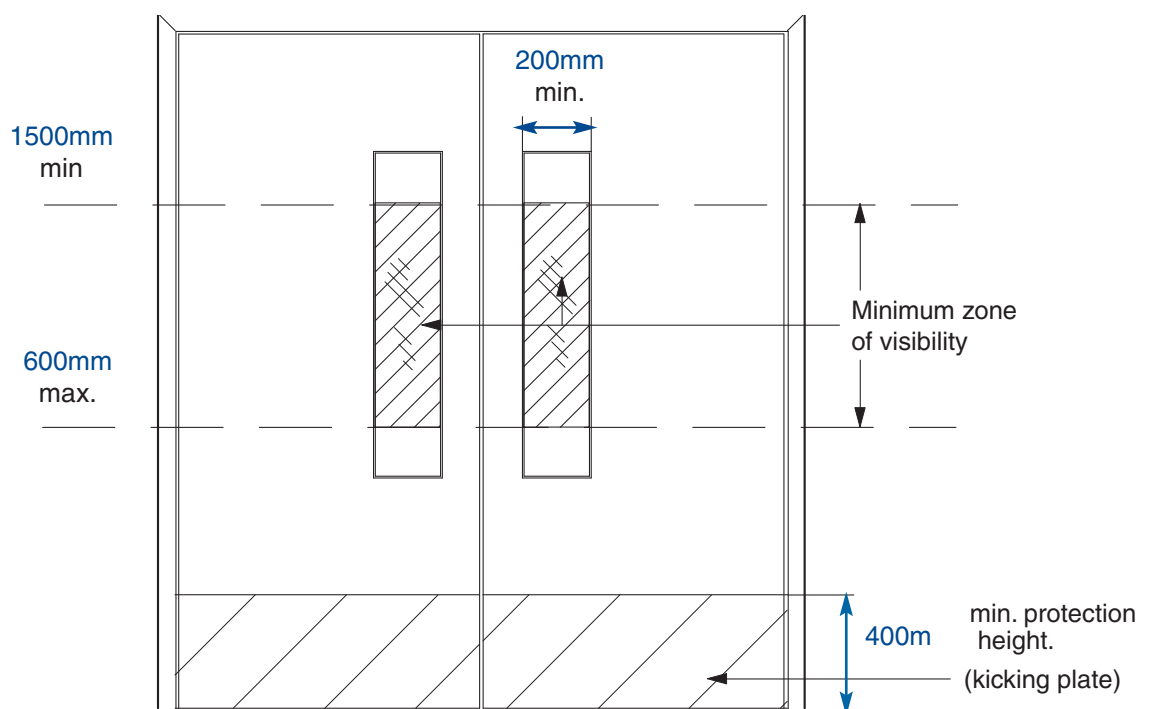

Doors

- Any double door set must ensure that the leading door has a clear 900mm opening width.
- All threshold must be flush throughout the interior of the building.

Door Closers

- Door closers must allow easy opening and closing with adjustment for strength ie. delayed action.
- Where pressure is greater than 22 Newtons use an electronic/hydraulic assisted mechanism.
- Door closers must allow opening and closing by use of low energy operating systems to provide an operating pressure of not greater than 22 Newtons. Any door with double swing action should not exceed 22 Newtons in either direction.
- The use of touch pad infrared sensor or hand set, or switch generated automatic closers should be considered according to the merits of the situation.
- Fire doors in corridors are to be held open with an electromagnetic device, but self-close when:
 - activated by smoke detectors linked to the door individually, or to a main fire/smoke alarm system.
 - power supply fails
 - activated by a hand operated switch
- Fire doors to individual rooms are fitted with swing-free devices that close when activated by smoke detectors or the building's fire alarm.

Kicking Plates

- Low level protection is necessary on all doors to ensure safety when used by wheel chair users.
- No edging should be installed below 400mm above finished floor level.
- Protection of the door to this height is adjustable by fixing kicking plates

Doors

Internal Doors

- 1000mm wide producing 900-860mm clear opening.
- Any double doorset must ensure that the leading door has a clear 900mm opening width.
- Ensure clear openings to pivoted and sliding doors (see Entrance Doors for applicable information).
- Thresholds should be flush throughout the interior of the building.
- Consider the use of hold-open devices linked to fire alarms, in circulation areas.
- Door closers to be fitted only when required for fire safety.

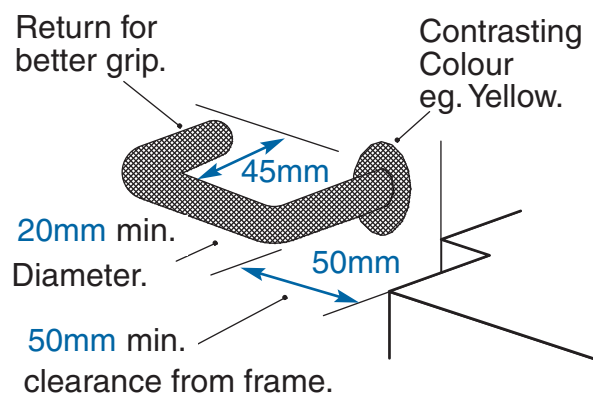
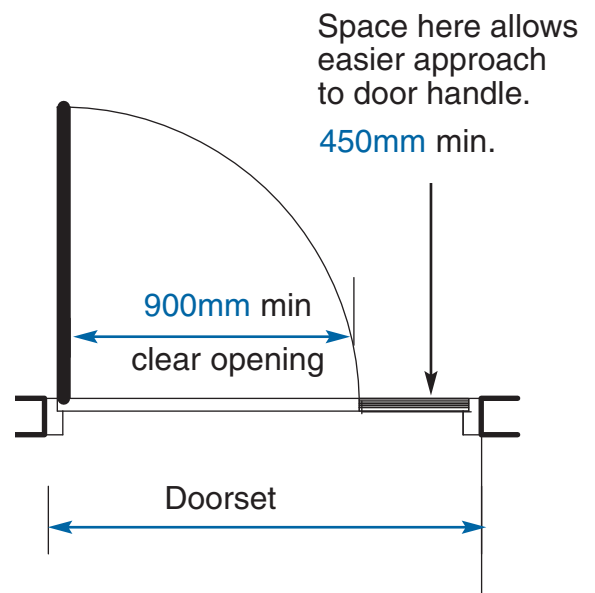
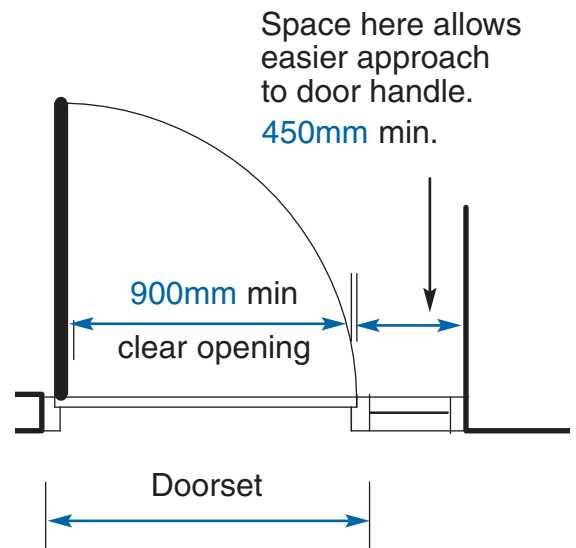

Lobbies

Lobbies

- As for entrance lobbies with double swing doors.
- Single doors, one opening in, one out should have minimum width of 1500mm, and 2100 minimum length of lobby.
- Where both doors open outwards the length can be 1500mm minimum.

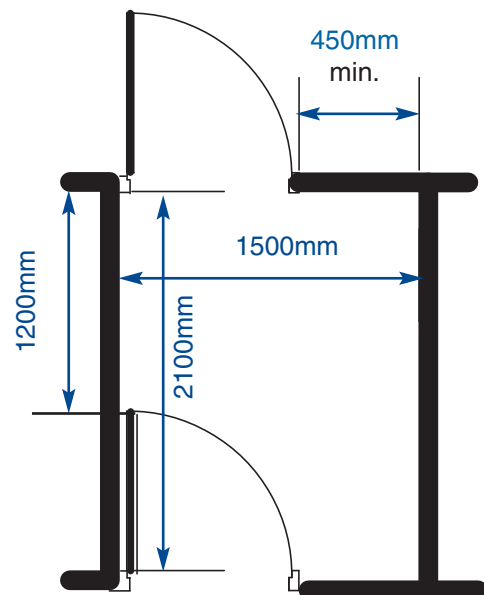

Circulation

Circulation

- Consider increased circulation and door opening widths, particularly in entrance areas of public buildings.
- A 450mm space to one side of doors eases approach and operation.
- Doors opening into routes may be hazardous, particularly if not self closing.
- Corridor widths should be unobstructed and obstructions recessed eg. Fire equipment.
- Colour and contrast should be carefully considered in relation to vertical (wall, doors etc.) and horizontal elements.
- Colour choice and surface texture can be used to signal where certain features can be found. For example, core walls housing access to lifts and stairs could be painted blue on each floor to help orientate people with a sight impairment or learning difficulty.
- Lighting should be located where it does not create glare or silhouettes.
- Wall and floor surfaces should be chosen to minimise light reflection and sound reverberation which can be confusing for people with sensory impairments.
- Floor surfaces should be smooth, even and non-slip. Heavily textured carpet or Flotex are unsuitable.
- Room numbering should be clear, consistent and well signed.
- Consider providing handrails in corridors.

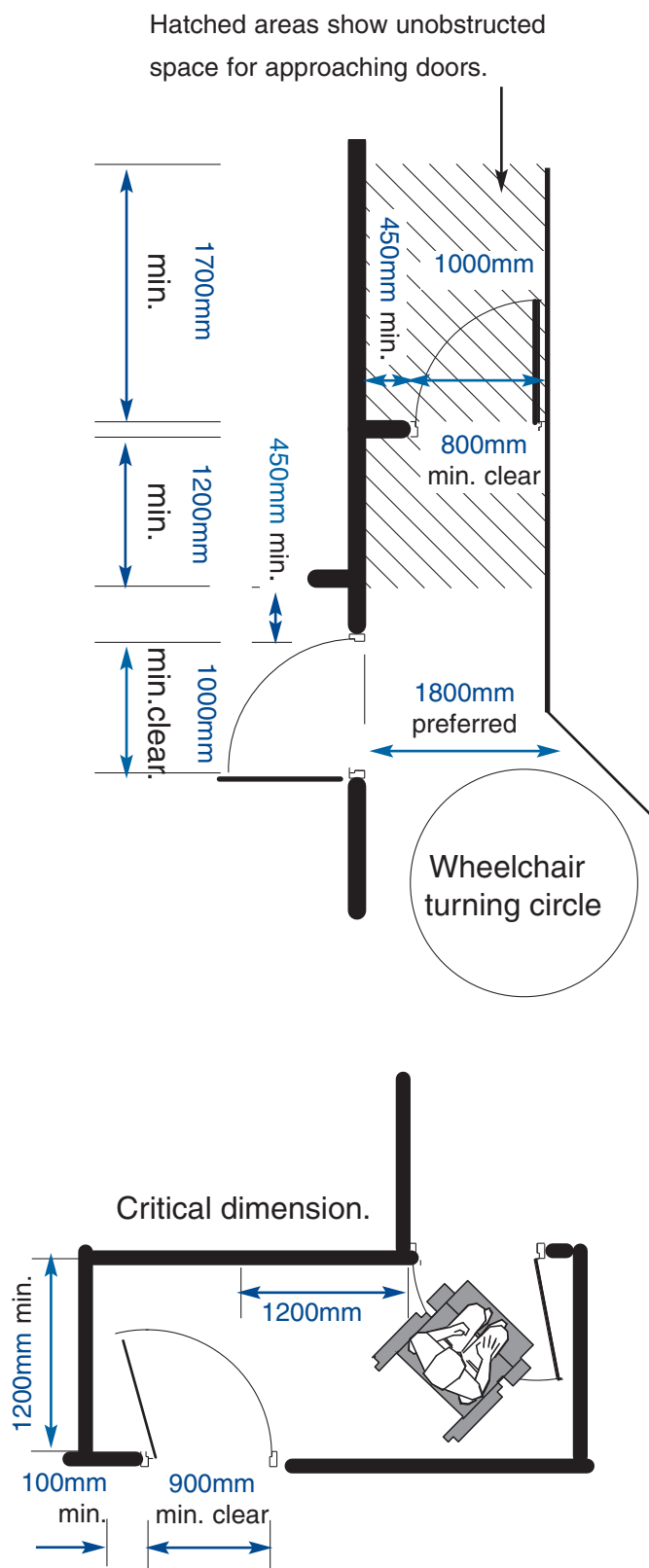

Lifts

- Multi-storey buildings must have at least one lift of sufficient size to be accessible by wheelchair users.
- Consideration must be given to making any accessible lift an evacuation lift in accordance with BS5588 and BS5588-8.
- Lifts or signs for the lift must be clearly visible from the principal entrance. All signs must incorporate the Internal Symbol for Access.
- Where a lift is used between two levels only, the doors should be on opposite sides to avoid the necessity for the wheelchair user to reverse out or turn around.
- Lift controls must be fitted between 900-1000mm and at least 400mm from any return wall.
- Consideration must be given for providing the internal control panel at an angle so that it can be seen and used from both a sitting or standing position.
- Do not use stairlifts or platform lifts in any new property.
- The lift door must be easily distinguishable from the adjoining walls and reveals to lift car.
- Doors must be in accordance with BS EN 81-70:2003 which recommend a minimum of 900mm clear opening.
- The floor of the lift must be a high luminance to ensure people with visual impairment that they are not stepping into an open lift shaft.
- All lifts must incorporate the following:
 - Audible and Visual indication of each floor and travel direction
 - Call buttons with symbols in relief to enable tactile reading
 - Alarm button fitted with visual acknowledgment that alarm bell has sounded. Emergency call number in clear print.
- Call buttons with symbols in relief and voice synthesiser to be incorporated in lifts.
- Touch light controls with both illuminated and audible information inside car and at landings.
- Controls 1000mm maximum height outside and inside lift.

Lifts

- Floor level indication should have raised (relief) numerals or letters. Both adjacent to lift controls and on walls opposite doors.
- Accurate levelling at landings.
- Hold button inside and outside lift.
- Photo Eye /Infra red device to override door closing.
- Clear landing in front of entrance: 1500x1500mm unobstructed waiting and manoeuvring space with distinctive textured floor surface.

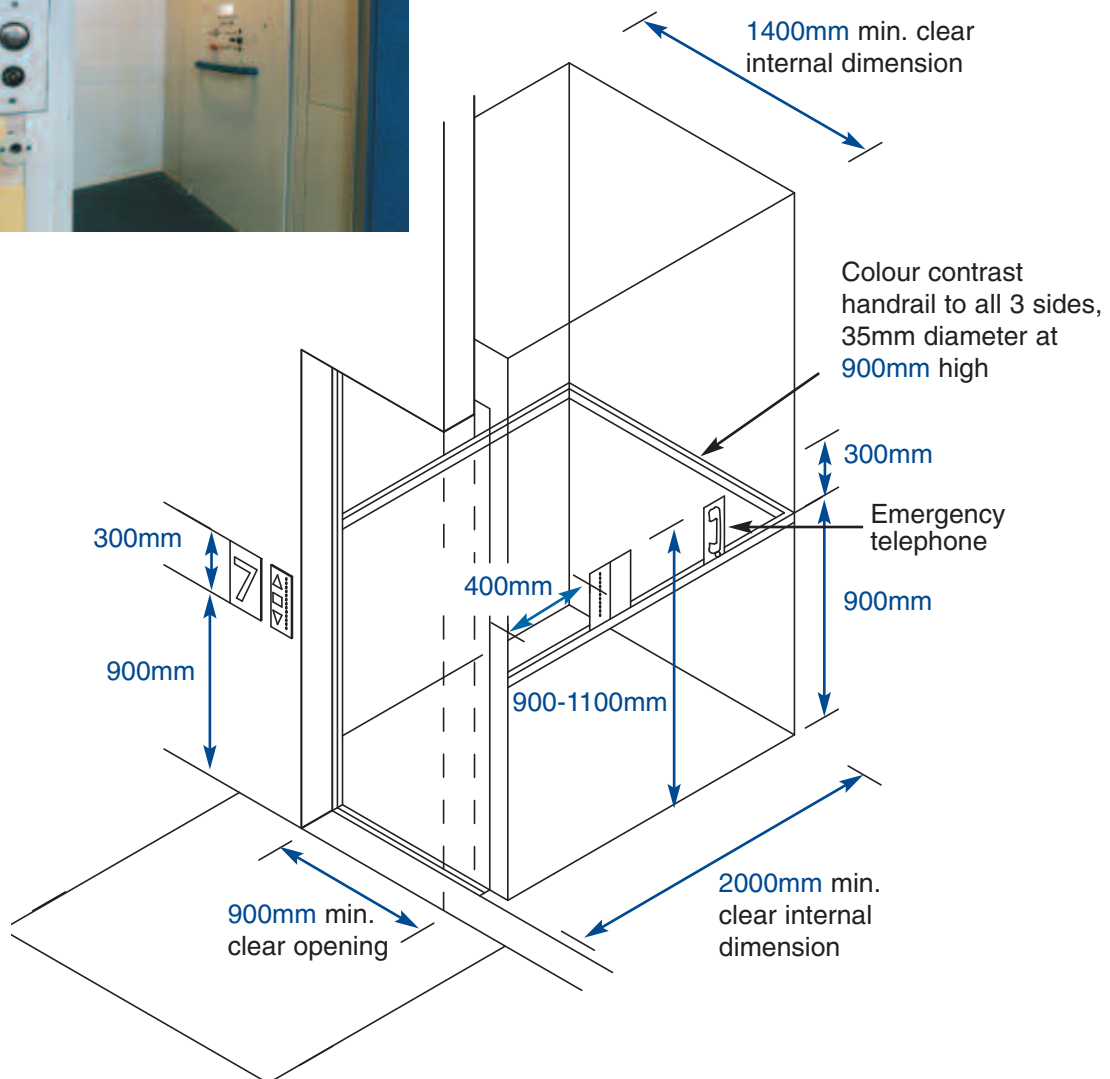

Lifts

- Signalling system must be incorporated which gives a 5 second notification that the lift is arriving at a landing call and a dwell time of 5 seconds before the doors close including voice/audible signal and visual signal.
- The call panel should be easily distinguished from its background.
- Inside the lift, the control panel should be located, if possible, on both side walls. Raised numbers on buttons help people with sight impairments; Braille is read only by a small proportion of people with a visual impairment.
- Outside the lift, the control buttons should be clearly distinguishable with “Lift coming” indication and clear visual and tactile indication of floor level adjacent to call buttons and opposite lift doors.
- Audible announcements of the floor reached are necessary for people with a visual impairment, visual displays are necessary for people with hearing impairments.
- A sign asking lift users to give Disabled people priority is helpful.
- Emergency telephones and speaker systems in lifts should contain inductive couplers so that hearing aid users can make use of them.
- Alarm buttons in lifts should be fitted with a visual acknowledgement that the alarm bell has sounded for lift users unable to hear it.
- The points identified in the section on external steps and ramps are relevant here.
- A mirror fixed to back wall of lift assists wheelchair users reversing.
- Handrails to three sides.
- Where a lift travels more than three storeys, consideration must be given to a fold down seat.

Escape Routes

Escape

- ESCAPE - BS.5588: Part 8 allows for evacuation of disabled people by a firefighter either manually or by lift. Pending arrival of evacuation team, disabled people and wheelchair users can either wait in safe refuges on staircases or in protected lobbies/corridors.
- Consider provision of fire fighting lift.
- Refuges - 700 x 1000mm minimum 900 x 1400mm preferred (includes manoeuvring space).
- Communication at refuge/lobby.
- Evac Chair - Position in refuge adjacent to lobby or as close as possible to Fire Exit door.
- Fire call points should be fixed at 900mm.
- On stepped exit routes fire evacuation signs should say clearly what wheelchair users or other mobility impaired people should do in the event of a fire.
- Visual alarms should be provided as well as audible alarms.
- Training for emergency evacuation should be in all premises. It is particularly important to consider the views of disabled employees when updating evacuation plans. Training should include use of pagers issued to Deaf employees and visitors for emergency alarms.

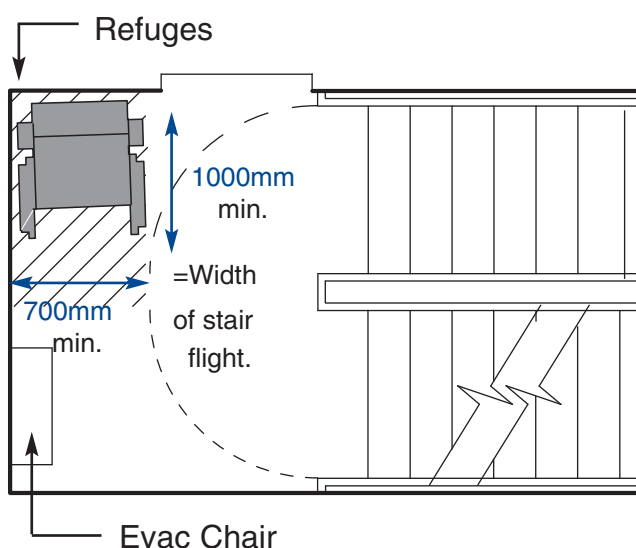

Vertical Rise Platform Lifts Section
Staircase with Wheelchair Platform

Stairlifts with Wheelchair Platform

- **These must only be used in exceptional circumstances in existing building and agreement obtained from Access Officer.**
- Must have a minimum platform dimension of 800 x 1250mm.
- All controls must be designed to prevent unauthorised use.
- There must be a communication with building staff.
- The platform must fold up and park with single push button operation.
- There must be 1500mm clear landing at both top and bottom to allow convenient manoeuvre onto and off platform.
- There must be consultation with Fire Officer before installation.
- The equipment must comply with Supply of Machinery (Safety) Regulations 1992, S1 1992/3073.

Vertical Rise Platform Lifts

- Must comply with Machinery Directive 98/37/EC and 3.B5 and 3.43 of Building Regulations Part M and Supply of Machinery (Safety) Regulations 1992.
- Must have minimum of 1000 x 1200mm platform for internal use 1050 x 1500mm platform where pavement scooters may be used.
- Joystick control of platform should be considered in place of push button.
- Must have minimum load of 400kg.
- An opening door/gate width of at least 800mm.
- Flush floor access to platform at each level.
- Remote button for door operation on each floor level.
- Automatic doors at each level with vision panel.
- Platform lift must be designed for independent use. All controls must be clearly visible and with clear instructions on use.
- Acceleration and deceleration rates must prevent jolting.

Toilet

Accessible Toilet

- Non-slip floor covering.
- Colour contrasting skirtings.
- No reflective floor or wall surfaces.
- Number and locations of WC provision must comply with Building Regulations Part M 2004. There must be at least one accessible WC located where there is sanitary provision.
- Toilets may have left-handed, right-handed or peninsular layout if assisted use possible. If two accessible toilets are provided one left and one right handed layout.
- All toilets should have accessible locks with large catch.
- Changing space should be provided for parents of Disabled children and where possible an adjustable changing bench for use by carers of Disabled adults.
- Baby changing areas should be separate if at all possible.

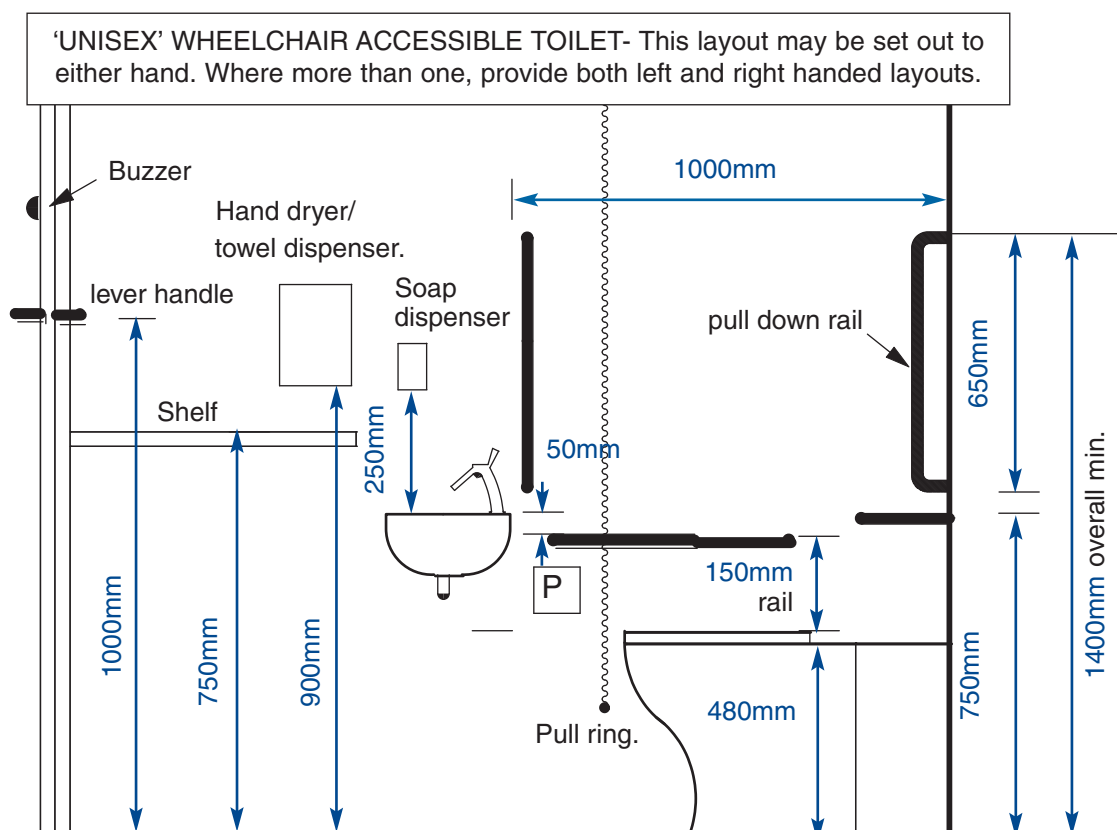

Toilet

Accessible Toilet

All to be in accordance with B.S 5810:1979 and part M of the Building Regulations

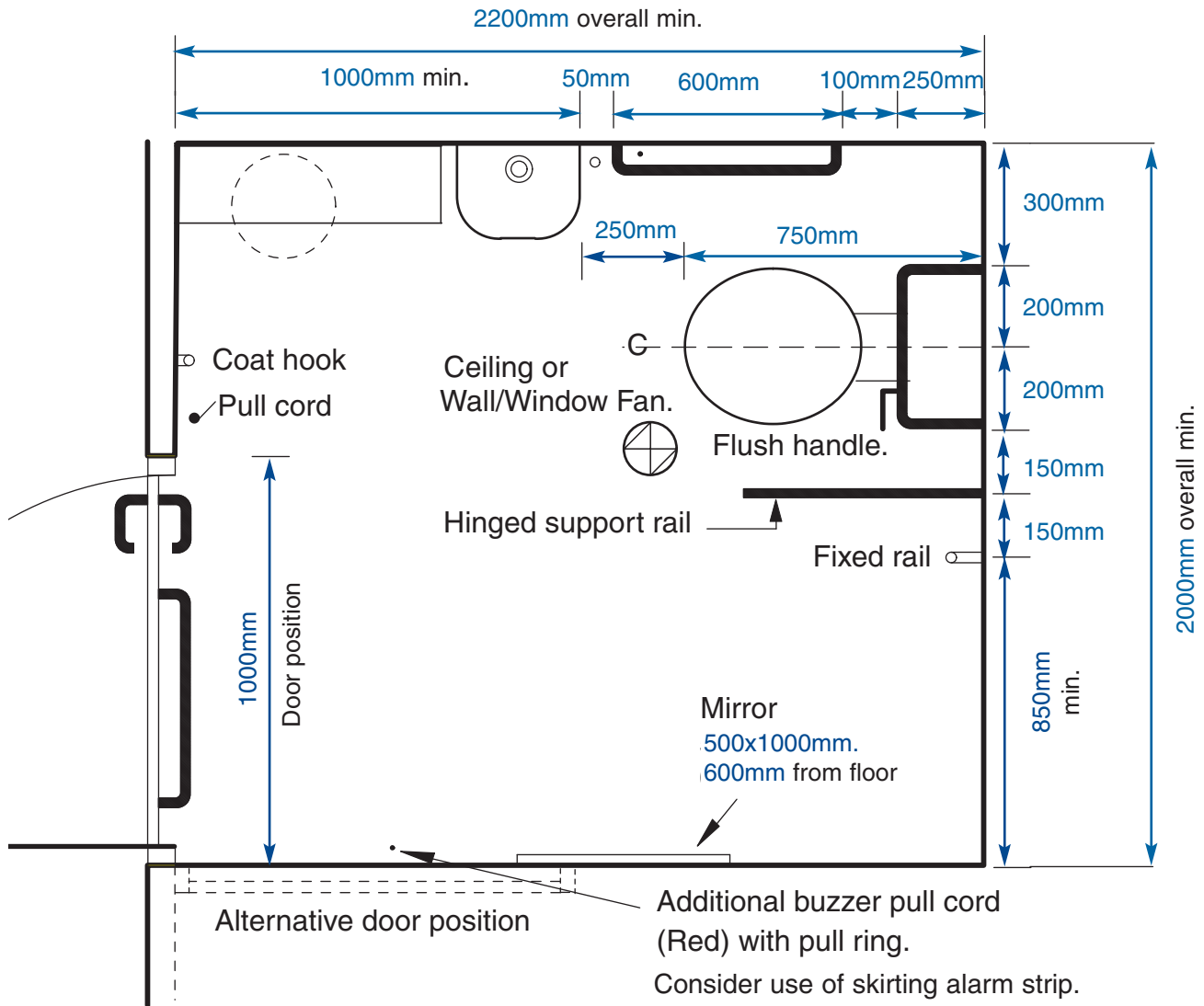

Toilet

Basin: Sited to allow it to be used together with related fittings and equipment from a seated position on WC.

Taps: Single lever mixer tap or sensor taps. Use a mixer valve to prevent burns - recommended maximum temperature is 41°.

WC: Seat should be closed type for ease of transferring. 480-500mm to top of seat is preferred by many for ease of transfer. Projection of pan from rear wall allows wheelchair to be backed against rear wall for optimum sideways transfer.

Door: Ensure internal space clear of door swing and fittings of 700x1100mm. Ensure door can open outwards in an emergency. If this is not possible, fit emergency door pivot set. For privacy and safety avoid opening direct into circulation areas. If inward or outward opening door restricts circulation then consider installing sliding door or bi-folding door. Fit rail or handle to inside of door to assist closing. Door preferably fitted on rising butt hinges i.e. not door closers.

Toilet Area

- Avoid boxed in pipework etc. that reduces space.
- Heavy duty toilet seat 25mm high.
- Securely fixed pan and heavy duty seat.
- WC flushing control on transfer side, broad spatula flush.
- Shallow handrise basin, single lever mixer tap.
- Soap dispenser - single handed operation 900mm high.
- Fixed rails, 35mm diameter, securely fixed.
- Hinged support rail at 700mm high.
- Alarm buzzer pull cord (red), to low level with ring and wall guide (where appropriate), and reset box at low level. Alternatively pressure rails mounted above skirting level eg. 300mm would be preferable.
- Single leaf doorset 1000mm wide, lever handle, closing pull, both at 1000mm high. Inside lock with large turn and outside quick emergency release. 400mm high kick plate.

Toilet

- Mirror 500mm wide x 1000mm high at 600mm from floor.
- Coat hooks at 1200mm and 1500mm approx. from floor level.
- Shelf for bags etc at 750mm high.
- Light switch/pull cord (white) at 800mm- 900mm high.
- Toilet roll single sheet dispenser preferred at 600mm high.
- Designate space for sanitary bin clear of door and WC.
- If space allows provide both hand dryer and paper towel dispenser.
- Allow for use of an emergency alarm system either pullcord or touch pad sensors.
- Alarm system to include visual alarm in toilets.
- Fire alarm system to include visual alarm in toilet able to be seen from all cubicles.



Toilet

Accessible toilet for ambulant Disabled people

A minimum of one adapted toilet for ambulant disabled people should be provided within each range of men's and women's toilets.

- **Doors:** Door may open inwards provided clear space is maintained and emergency outward opening is included. Door swing clear of fittings should be at least 700 x 1100mm.
- **Colour:** The colour or tone of the background should allow for easy distinguishability of grab rails and sanitary fittings.
- **Layout:** Where several unisex or ambulant WC's are provided the opportunity should be taken to provide both right and left handed layouts.
- **Seat:** May use a raised toilet seat to obtain the height requirement and use heavy duty seat.

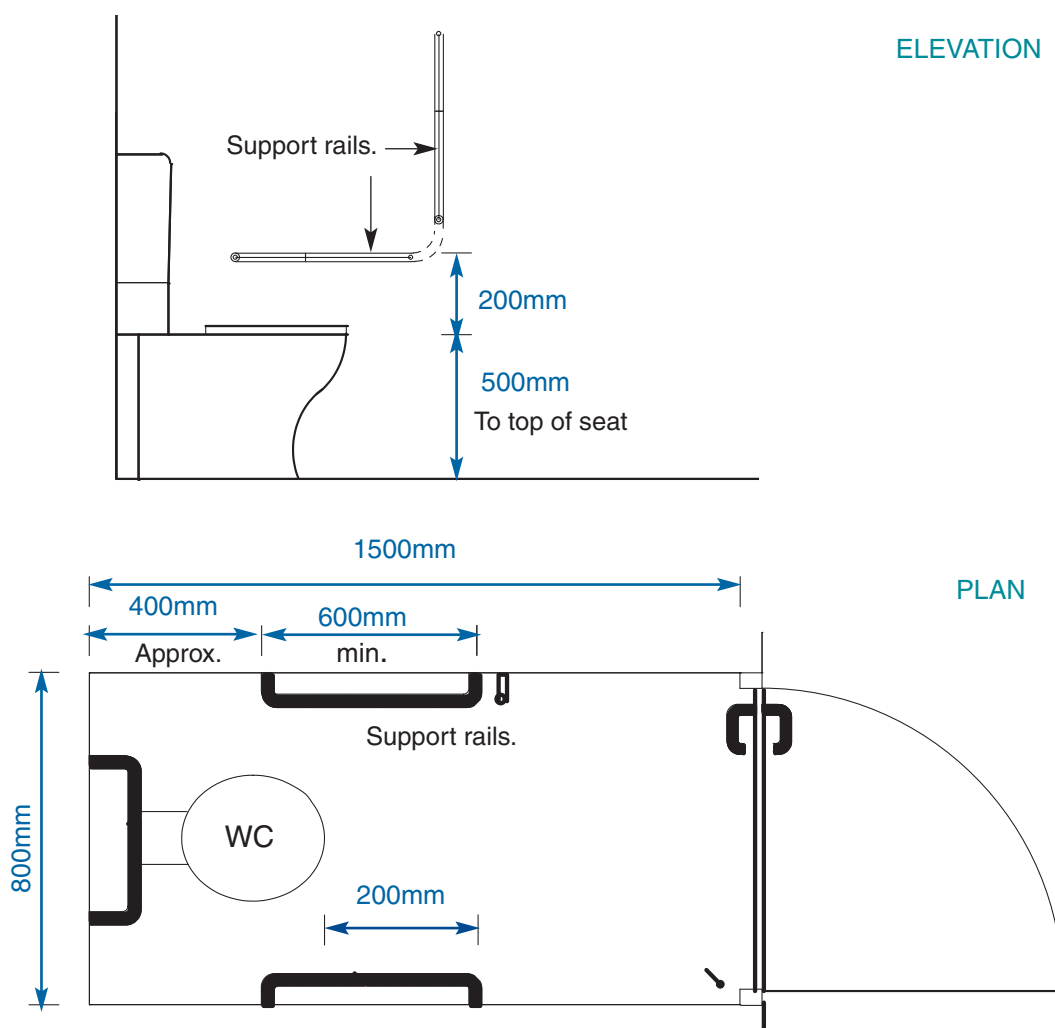

Signs

Sign specifications

Signs - should be consistent, thorough and continuous along routes and should take account of the need for reassurance.

- Ensure the lettering is a strong colour contrast to the background and that the size is in strong contrast to the surrounding area.
- Lettering should be done in lower case with initial capitals eg 'Exit' 'Toilet', using a sans serif font, minimum height of lettering 50mm e.g. Arial or Helvetica. Use directional arrows if relevant.

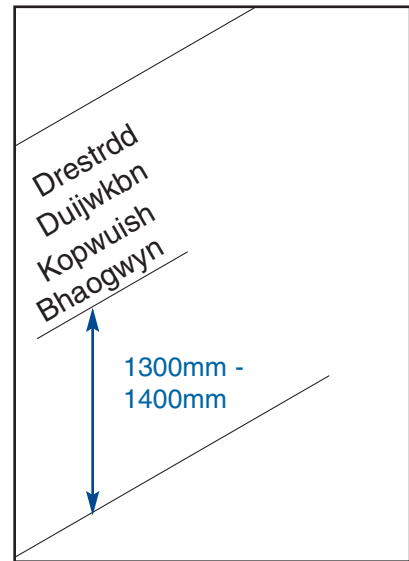

Tactile Letters are particularly helpful to blind people. Tactile letters - the sign can include text symbols and braille and must be embossed (raised), with a height between 1 -1.5mm

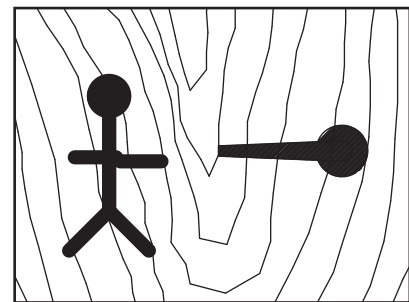

Braille - Signs should be located by lift buttons. Consider use of speech synthesizer.

Symbols - should be as near pictorial as possible. Standard symbols should indicate specific facilities eg. induction loop (see below) information, communication, assistance available if required.

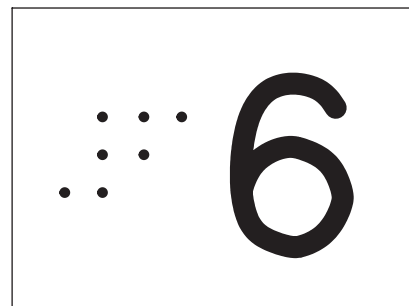

- Entrance intercoms are a problem for deaf people - consider provision of lights to indicate 'Speak now' and 'Enter', located at suitable height for wheelchair users.
- Use symbols where possible.

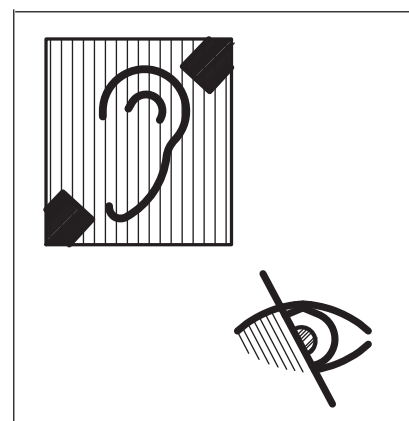

Signs

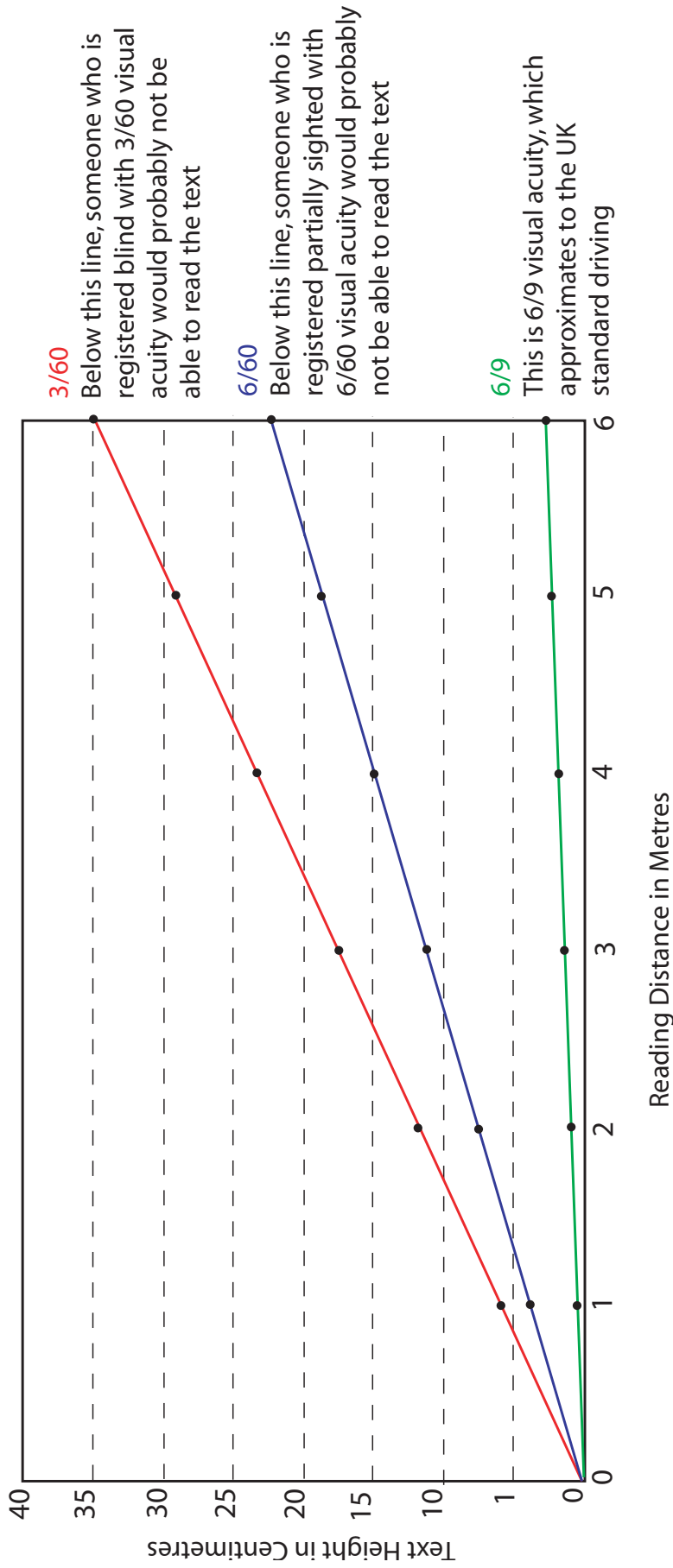

Signage

- All signs must be - **Clear - Concise - Consistent**
- A good signage scheme must work in conjunction with orientation clues provided by the site to make the identification of and the direction to certain key destinations.

Provide Signage for:

- **Information** - To aid orientation, identifying main locations, covering the whole site internally and externally.
- **Direction** - Used to direct users to destinations using arrows and directional text. When used in a bank of signs care has to be taken with use of arrows to avoid confusion.
- **Identification** - Installed at individual destinations to indicate the location of a room, facility or service once a destination has been reached.
- **Safety and Mandatory** - These are used for the safety of users and can be either warning or prohibitions signs.
- Ensure that all text is of a sensor type face.
- Lettering to be lower case with initial capital eg. Exit. Toilet.
- Use text and symbols where possible.
- Where possible the face of the sign to be 45 - 60 degree incline from horizontal.
- Text to be aligned on the left hand side of the sign. For direction signs, text to range accordingly to direction of arrow.
- Ensure consistent line spacing, people with visual impairments need a 15 - 20 percent increase in line spacing.
- Ensure maximum of 12 - 14 letters (2 or 3 words) per line, depending on type face.
- Ensure contrast between all elements of a sign:
 - between the background (brick, tree etc.) and the sign board.

Signs

- Between sign board and the text or symbol on it.
- Minimise glare:
 - Use materials with a matt finish.
 - Do not suspend signs against a light source eg. windows, glass doors or against overhead light fittings.
 - Do not position signs directly on external; glazing.

Positioning of Signs

- Rooms identification signs to be fitted on wall beside latch side of door (except toilet and washroom doors).
- Signs that are accompanied by a control panel must be between 900 - 1200mm above finish floor level.
- Signs that are to be read at a long range must be positioned to make the sign obvious and that it cannot be obscured by intervening objects ie. lorries, cars, beams.
- Signs to be read at medium range must be positioned to prevent them being obscured by people congregating nearby.
- Overhanging or projecting signs must be positioned 2300mm to the underside from finished floor level.
- Signs that are to be read at close range must be between 1400 - 1700mm.
- Signs must be located so that they allow the person to approach and touch the sign. Users must not encounter protruding objects or stand within the swing door.
- Consult the* “Sign Design Guide” for full information on location and size guidance.
- Consult Bristol City Council, published ‘Visual Identity and House style” to follow corporate guidelines.



* see publications section

Signs

Counters

- Induction loop facility should be provided and well signed.
- Curved lip to counter preferred at outer edges and changes in counter level.
- Contrast top and edges of counter.
- Exposed angles to be well rounded.

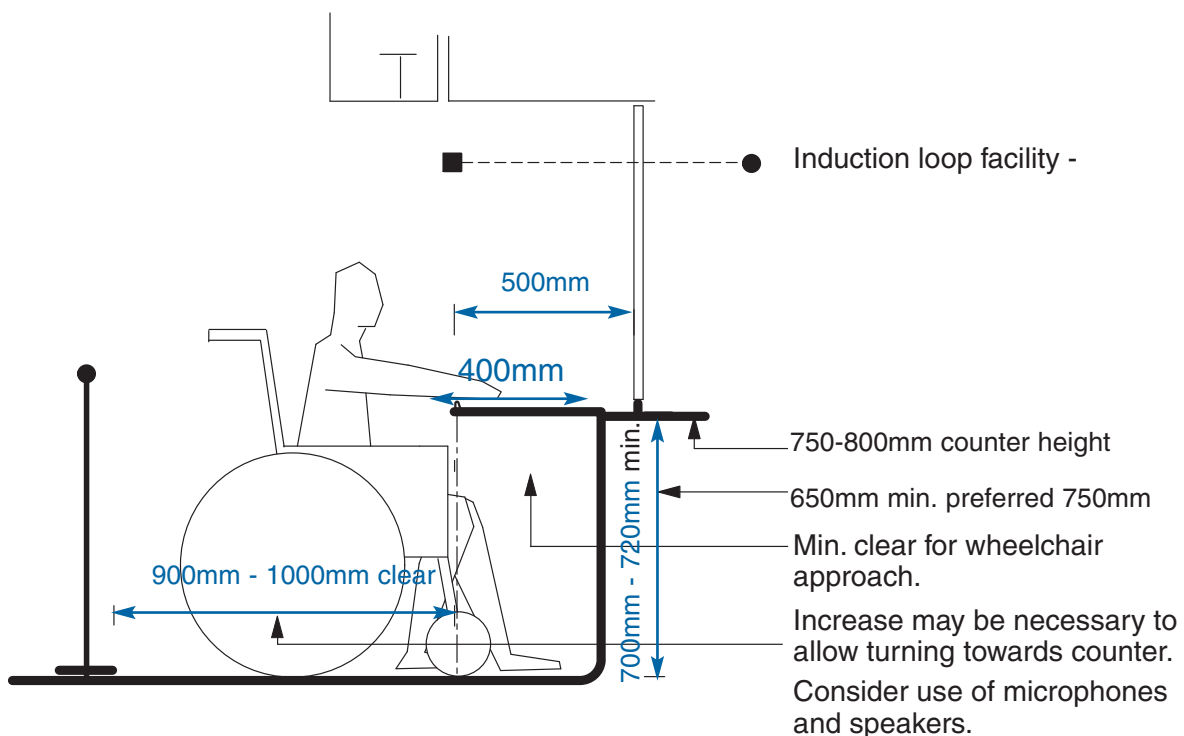
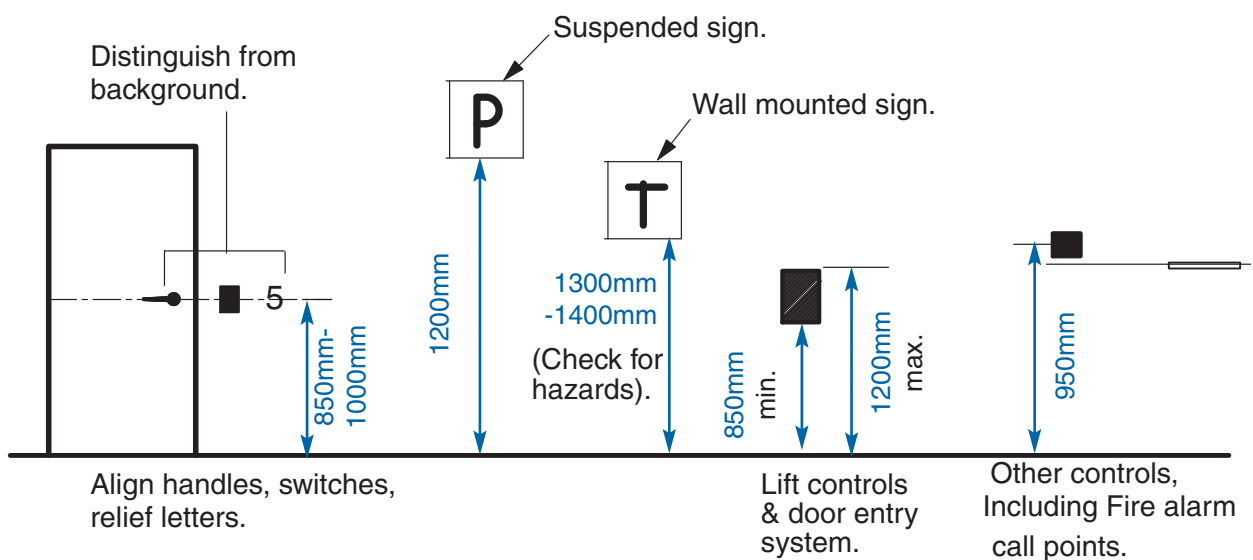

Equipment

Office equipment

- Telephones- no higher than 1200mm to topmost control of unit including card slot.
- Flexi-time clock - No higher than 1100mm to topmost control of unit, including card slot (Digital display to be near vertical).
- Facsimile unit - No higher than 900mm to topmost control of unit, including card slot.
- Photocopier - No higher than 900mm to top of unit. Card slot to be at front of unit.
- Power sockets should be wall or workstation mounted to be easily accessible - floor sockets are a hazard.
- Power sockets should be between 900mm and 1200mm high.
- Offices should have at least 1200mm clearance between desks.
- 2 or 3 drawer filing cabinets are preferred.
- Consider acoustics to avoid excessive background noise or echo.
- Display and notice boards should be at an accessible height.
- Minicom (textphone) fax and / or email should be offered as an alternative to phone communication.

Lighting

- Lighting should be even and non-glare - avoid pools of light and shade.
- Additional task lighting is helpful to people with a hearing impairment.
- Lighting should be 300 lux minimum.
- Fluorescent lights (including low energy) should not be used near induction loops as they cause interference.
- Light switches should be no higher than 1200mm and easy to use (eg. large rocker switches).
- Consider using switch free systems (eg movement sensors).

Hearing Enhancement Systems

- ADM requires that hearing enhancement systems be installed in rooms and spaces designed for meetings, lectures, classes, performances, spectators sports or film, and at service or reception counters where they are situated in noisy areas or are behind glazed screens. The presence of an induction loop or infrared system should be indicated by the standard symbol.

Noise Reduction

- Consider areas where communication will be important, such as reception desks. Locate these away from potentially noisy areas of the building.
- Adequate sound insulation must be provided to minimise intrusive noise, both from outside and within the building.
- Hard surfaces, which cause problems for people with hearing impairments must be avoided.

Induction loops

- Induction loops should be provided in reception areas and meeting rooms and where appropriate in working areas.
- Most induction loops use an insulated cable laid around an area with a microphone. The loop sets up a magnetic field so that a person using a hearing aid with a pick-up coil can receive sound without distortion.
- Specialist advice is needed where security or confidentiality needs to be maintained.
- Infra-red loops can be used where confidentiality is important but are less reliable than magnetic systems.
- Staff should be trained in the effective use of loop systems and ensure that they are switched on.
- Induction loops convert sound via microphone into a varying magnetic field, which is converted back to amplified sound by an individual's hearing aid (where a 'T' switch is fitted). Loops help to cut out extraneous background noise.

Equipment

- Induction loops should be fitted wherever information is given verbally: airports, railways stations, box offices, ticket counters, banks, post offices, churches, meeting rooms, cinemas and theatres.

Infrared Systems

- Infrared systems work on different principles by converting a sound source into an infrared light signal, and require special receiving headsets. This system is more suitable for controlled areas such as cinemas, theatres and lectures rooms, where headsets can be borrowed from a central source. The system is of particular value where confidentiality is important. As the technology is based on light, sound cannot be picked up outside the room in which the infrared signals are generated.
- Infrared systems cannot be used.

FM Radio Systems

- FM radio systems can be used in situations where a loop, infrared or sound reinforcement system is not available. Using a licence-exempt FM radio link, the transmitter and receivers are lightweight and compact can be worn under clothing. Receiver units have a thumb-wheel volume control, and both units have power 'on' indicators.
- The systems can be used with a supplied earphone/headphones or with a neckloop (hearing aid switched to 'T') for extra seclusion and clearer sound. The range is up to 30m. This type of system is particularly suitable for training and educational purposes.

Aids and Equipment

Consideration of certain elements in the layout of space and provision of equipment can make a great improvement to the use of any built environment. The chief elements may be:

- General spaces.

Is it necessary to modify existing space or to reduce group sizes to accommodate disabled people ?

- Specialist spaces.

How can areas be used flexibly? Should new rooms be created to provide the specialist spaces needed, such as rooms for physiotherapy or counselling, medical rooms, storage for equipment and so forth?

- Physical movement.

Can all people with mobility difficulties get to, in, around and safely out of the building or space?

- Wayfinding.

Can people orient themselves and find their way around the buildings and grounds?

- Visual aspects.

Are lighting levels, colours and other visual aspects designed to help people, especially those with visual impairments, participate as fully as possible?

- Acoustics.

Are acoustic conditions designed to help people, especially those with hearing impairments and other sensory impairments, participate as fully as possible?

- Sensory environment and temperature.

Does the current environment provide stimulating sensory experiences and comfortable temperatures for all people?

- Furniture and equipment.

Does any furniture need to be adjusted or suitable equipment provided to enable people to participate as fully as possible?

Equipment

Switches and Controls

- Location and detailing of switches and controls should take into account ease of operation, height distance from corners, visibility and unobstructed access.
- See Counters section (p49) for heights of various different kinds of switches, controls and sockets.
- The operation of switches, sockets and controls would not require the simultaneous use of both hands. Large switch pads are to be used where possible.
- Flushed or recessed controls must be avoided as these are not accessible to people with limited background.
- Colour and tonal contrast must be used to ensure controls are distinguished from their background.
- Ensure that switched socket outlets, mains and circuit isolator switches indicate clearly whether they are 'on' or 'off' (red and green colour indication, if used, should be supplemented by text or pictogram indication).
- Consider the use of tactile buttons and controls. These must be embossed, not engraved.

Open Spaces Specifications

General requirements are set out here. However, acknowledging that the nature of open space can vary, variable standards are given in 6.2.6 which apply in different settings. Where maximum ramp gradients are given, for example, these are the preferred maximum, as the topography may constrain this. There will always be a need for site specific solutions, but the solution should maximise accessibility.

The design principles here as a minimum meet, and in some cases exceed, the guidance in the 'Countryside for All' good practice guide on access to the countryside. This document gives more detailed guidance and can be read alongside the BCC access standard. Reference should be made to the principles and guidance given in "By all reasonable means: inclusive access to the outdoors for disabled people". The Countryside Agency Oct. 2005

Surfaces

- Surfaces should be firm, stable, nonslip and obstacle free.
- Suitable materials include concrete, tarmac, stone and paving. Concrete can be lightly textured to prevent it becoming slippery. Paving needs to be evenly laid and closely bonded to avoid gaps and uneven areas.
- Sand, loose gravel, cobbles, setts and woodchips are unsuitable.

Clearance

- Space directly above a path needs to be at least 2100 mm high.
- Objects such as signs which overhang paths below 2100 mm should be replaced with posts at least 1000mm high which can be located by cane users.

Bridges / boardwalks

- Minimum clear width should be 1200mm.
- Boards should be laid at right angles to pedestrian flow.
- At the start of a boardwalk, the upstand should be 5mm or less.
- Edges should be defined by a rail no higher than 75mm from the boardwalk surface, or an upstanding edge of at least 75mm.
- Timber used should be tested for slip resistance, and treated if necessary.

Open Space

Ramps / steps

- Where a ramp is provided it should conform to the maximum gradient for the setting.
- Steps are preferred by some ambulant disabled people - where these are provided as well as a ramp these should have handrails, textural changes at top and bottom (see 'External steps').
- Steps should not be used without alternative access by ramp.

Pedestrian and Cyclist paths

In general all cycling should be achieved on-carriageway in accordance with the principles and guidance established by the Department for Transport. See guidance on this from LTN 2/86 and LTN 2/04 Adjacent and Shared Use Facilities for Pedestrians and Cyclists, also LTN 1/04 Policy, Planning and Design for Walking and Cycling.

A route should therefore be segregated from a footway if:

1. High flows of pedestrians or cyclists are expected
2. Disabled people or other vulnerable users are likely to use the facility frequently
3. There is insufficient width available to do so anyway

The route may not be segregated if the equal and opposite applies.

All sites are individual and should be assessed on their own merits. Issues to be addressed that may affect the assessment are elements such as likely terrain, surface treatment, location and destination e.g. routes to historical monuments, scenic sites and attractions with clear signage. Where sufficient width is available segregation should be achieved with either indicative barriers e.g. interrupted rail or planting systems or a defined level change of 50mm – 100mm.

Sufficient width should be gauged by evaluation of the local situation against the ideal minimum width of 5000mm. Footway width of no less than 2000mm and a cycle lane of no less than 3000mm. Further reference should be made to the section: Open Space – Landscape Settings (page 60).

Under extreme circumstances a footway width of 1500mm is acceptable for short stretches of a route. Similarly a cycleway width of 2000mm can be used where there is no option on a short length of a route. Single direction cycleways of 1500mm would be regarded as a minimum provision in all cases.

Barriers and Gates

- No barriers should be used on paths unless there is a proven need to exclude vehicles or animals.
- Only use barriers where consistency is possible - eg. not on paths with open access at other points.
- Use the minimum level of barriers possible and use enforcement and management instead wherever possible.
- Where barriers are needed, consider withdrawing them once use of the route is established.
- To deter vehicle use, consider using several barriers close together at the path entrances and leave intervening areas free of barriers.
- Where a path is a public right of way alterations will require the consent of the highway authority and public consultation.
- Where a barrier is needed to exclude vehicles or animals these should be designed to allow access to wheelchairs and scooters.
- Barriers opened with a RADAR key are unsuitable in general because they are not accessible to everyone. At certain sites they may be appropriate as a supplementary gate.
- Accessible barriers include:
 - countryside for all gate;
 - wheelchair kissing gate;
 - York type barrier;
- Stiles should not be used - gates are preferred.

Open space

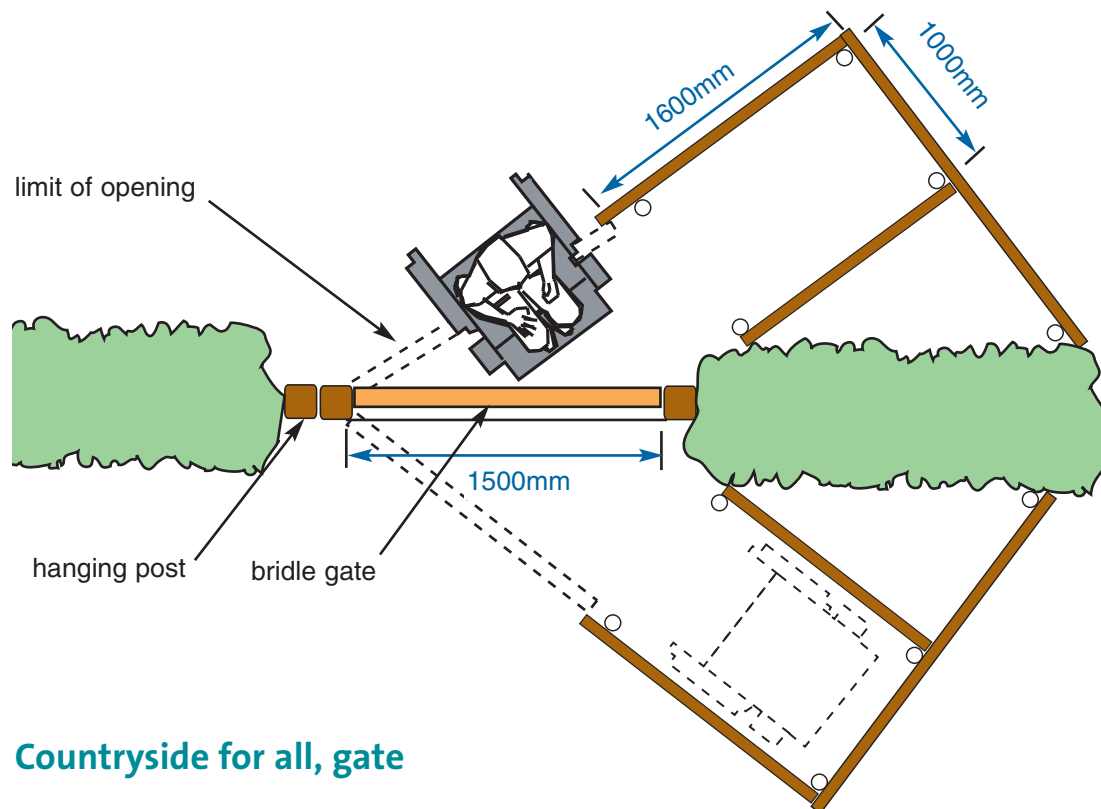

Countryside for all, gate

This gate works using either a conventional farm gate or bridle gate. The basis of the gate is a self closing hinge which always brings the gate to rest in a central, closed position.

- The side bays are constructed from post and rail fencing. There should be a bay each side of the gate. People using the gate lift the vertical bolt and push the gate away until it reaches the stop. The entry to the bay is then open. The user then moves into the bay and releases the gate. The gate swings to the central position and leaves free access from the bay. The gate will swing both ways and the two boxes mean it can be used from either direction.
- The gate can be made shockproof by the addition of a rise and fall bolt and keep ramps. These wedge shaped ramps are fixed about 200-300mm apart and bolted to a piece of timber securely pegged to the ground. As the gate closes the bolt rises over the first ramp and is then trapped between the two.

Open space

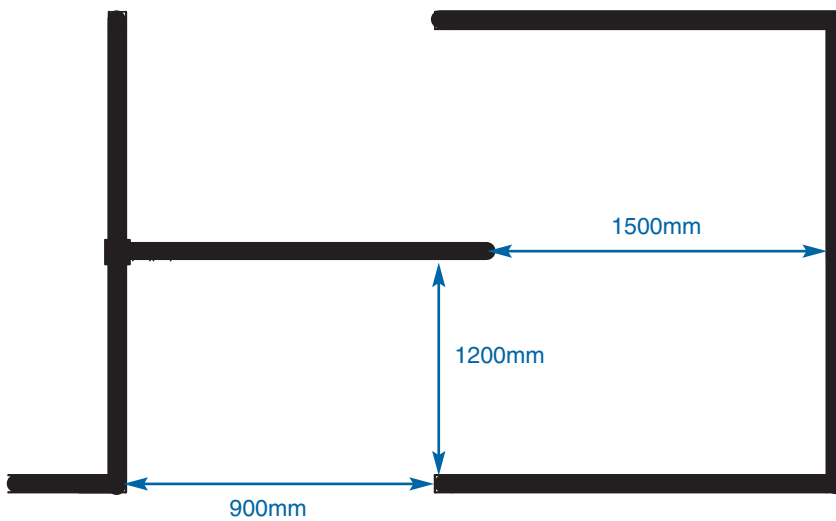

Minimum dimensions for a barrier opening on pathways for pedestrian use.



This gate can be constructed in differing materials to suit the context

Hinged operation and latches should be used only as a resort if fixed position barriers are not adequate.

Barrier changes should be done with the advice of disabled people and the Access Officer.

Note should be taken of the recommendation in the guidance published by the British standards Institute, 'Gaps, gates and stiles-Specification' (BS 5709:2001 and BS8300).

Open space

Landscape settings

Different specifications apply in different settings, which can be roughly divided into:

- urban and formal landscapes;
- urban fringe and managed landscapes;
- rural and working landscapes.

One large site - for example - Ashton Court - may contain elements of more than one kind of landscape.

Urban and formal landscapes

- Hard, firm and smooth surfaces with very few loose stones, none bigger than 5mm.
- Paths at least 2000mm wide. Obstructed paths should retain a clear minimum width of 1200m
- Passing places provided at 50m intervals.
- Resting places provided at 100m intervals.
- Ramps 1:20 maximum.

Urban fringe and managed landscapes

- Hard, firm and smooth surfaces with very few loose stones, none bigger than 10mm.
- Paths at least 2000mm wide. Obstructed paths should retain a clear minimum width of 1200m
- Passing places provided at 100m intervals.
- Resting places provided at 200m intervals.
- Ramps 1:20 maximum.

Rural and working landscapes

- Hard and firm and smooth surfaces with some loose stones, not covering whole surface, none bigger than 10mm.
- Paths at least 1000mm wide.
- Passing places provided at 150m intervals.
- Resting places provided at 300m intervals.
- Ramps 1:12 maximum.

Signing and wayfinding

General advice is given in section 8. In open spaces:

- Use signing on routes to inform users of distances, gradients, surfaces, other users and distance to seating and toilets.
- Signing should be consistent - for example providing directional signs at all junctions on routes.
- Signs should be placed so as not to obstruct the path. Information boards should have clear and accessible surfaces around them and have non-reflective surfaces. Consider providing shelter at major information points.
- Information provided should include accessible routes, the location of facilities, public transport connections and car parking.

Play facilities

- Play facilities should be inclusive so that facilities for disabled children or disabled parents and carers are integrated into mainstream provision.
- All play facilities should include accessible play equipment.
- Consider the setting - entrances to play areas and routes through should be at least 1600mm wide and surfaces should be accessible.
- Provide seating for carers near play equipment at varying heights and consider providing some sheltered seating.

Seating and picnic tables

- Seating and picnic tables should be designed so that disabled people can sit with non-disabled companions. This may require the provision of a range of designs.
- Provide a range of seating at varying heights, some with armrests.
- Provide accessible space next to tables and seats for wheelchairs - firm, stable, flush with path and at 1000mm square.
- Set back seating from routes by at least 600mm.

Publications

Publications

Bristol City Council Publications

Available from the Scrutiny and Equalities Unit -
see Contacts below:

Accessible Meetings and Information

Integrated Equalities Policy

**Improving the Employment of Disabled People -
Good Management Practice Guide**

**Disability Discrimination Act - A Short Guide to the Act and
Your Rights**

**The Disability Discrimination Act 1995 Policy Statement and
Action Plan 2001 - 2003**

Centre for Accessible Environments Publications

Available from Centre for Accessible Environments -
see Contacts below:

**Access Audits - a guide and checklists for appraising the
accessibility of public buildings**

**Designing for Accessibility - an essential guide for public
buildings**

**Good Loo Design Guide - advice on WC provision for disabled
people in public buildings**

Access to ATM's: UK design guidelines, 2002

Reading and Using Plans

Access by Design - quarterly journal

Publications

Other publications

Designing to Enable - Improving Access Through Consultation.

Gateshead Access Panel
John Haswell House
8/9 Gladstone Terrace
Gateshead
Tyne & Wear
NE8 4DY

Building Regulations 2000 Part M - Access and Facilities for Disabled People.

The Stationery Office
PO Box 29
Norwich
NR3 1GN
Tel: 0870 600 5522
Fax: 0870 600 5533

Inclusive Mobility, A guide to best practise on access to pedestrian and transport infrastructure. Product code IM/01

Philip R Oxley
Mobility & inclusion Unit
Dept. for Transport
Tel: 0870 1226 236
Minicom: 0870 1226 405
Email: dft@twoten.press.net

BT Countryside for All Standards and Guidelines.

The Fieldfare Trust
67a The Wicker
Sheffield
S3 8HT
Tel: 0114 270 1668
Fax: 0114 276 7900
Minicom: 0114 275 5380
email: fieldfare@btinternet.com

Building Sight - A handbook of building and interior design solutions to include the needs of visually impaired people.

RNIB
224 Great Portland Street
London W1N 6AA
Nutmeg House
60 Gainsford Street
London SE1 2NY
Tel: 020 7357 8182
Fax: 020 7357 8183
email: cae@globalnet.co.uk

Provides training and publications on access issues, and a register of access auditors and consultants.

Disability Rights Commission

Freepost
Sitel House
Stratford-on-Avon
CV37 9BR
helpline: 08457 622633
email: www.drc-gb.org

Publications

Landscape Access Recreation - By all reasonable means.

John Dower House
Crescent Place
Cheltenham
Glouc. GL50 3RA
tel: 01242 521381
fax: 01242 584270
email: www.countryside.gov.uk

University of the West of England

Faculty of the Built Environment
Coldharbour Lane
Bristol
BS16 1QY
Fax: 0117 344 3002
email:
sandra.manley@uwe.ac.uk

Sources, Useful Contacts and Links

Access by Design - Journal of the Centre for Accessible Environments.

Access Journal - Journal of the Access Association
Building Regulations (2000) - Approved Document Part M.

BS 8300, 2001 - Code of Practice for design for building and their approaches to meet the needs of disabled people, British Standards Institute.

Designing for Accessibility - An essential guide for public building, 1999, Centre for Accessible Environments.

Disability Discrimination Act. 1995, The Stationary Office.

Disability Discrimination Act. 1995, Code of Practice: Rights of Access, Goods, Facilities, Services and Premises, The Stationary Office.

Easy Access to Historic Properties, 1995, English Heritage.
Inclusive Design Report - DRC

Lifetime Homes Standard, 2000, Joseph Rowntree Foundation.

Planning and Access for Disabled People : A good practice guide, 2003, Drivers Jonas for Office of the Deputy Prime Minister, London.

Sign Design Guide - A guide to inclusive signage, 2000, Peter Barker and June Fraser, John Moores University and the Sign Design Society.

Town & Country Planning Act, 1999, The Stationary Office.

Links

Centre for Accessible Environments	www.cae.org.uk
disability Rights Commission	www.frc.org.uk
DPTAC - Access for All	www.dptac.gov.uk
Office of the Deputy Prime Minister	www.odpm.gov.uk
Radar	www.radar.org.uk
Royal National Institute of the Blind	www.mib.org.uk
Social Exclusion Unit	www.socialexclusionunit.gov.uk
Access Association	www.access-association.org.uk

Glossary of terms

BCC	Bristol City Council
BPAC	Bristol Physical Access Chain
CAE	Centre for Accessible Environments
DETR	Department of the Environment, Transport and the Regions
DDA	Disability Discrimination Act
DRC	Disability Rights Commission
IEP	Integrated Equalities Policy
mm	millimetres
m	metres
min	minimum
max	maximum



