



All England Concessionary Travel Scheme

Application Form for Older Persons - New applicants only

The Government has announced that the qualifying age for concessionary bus travel will rise from 60 to 65 over a ten-year period from April 2010. To find out how this change will affect you please refer to table on page 1.

This form together with original documents supporting your application, can be taken to any of our Customer Service Points. If you are unable to submit your application in person, please post the form and original documents to the address provided. These will be returned by recorded delivery.

CHANGES TO ELIGIBILITY FOR DIAMOND TRAVELCARD

starting April 2010

The Government has announced that the qualifying age for concessionary bus travel will rise from 60 to 65 over a ten-year period from April 2010.

DATE OF BIRTH	DATE OF ELIGIBILITY FOR DIAMOND TRAVELCARD
on or before 5 April 1950	date of 60th birthday
6 April 1950 to 5 May 1950	6 May 2010
6 May 1950 to 5 June 1950	6 July 2010
6 June 1950 to 5 July 1950	6 September 2010
6 July 1950 to 5 August 1950	6 November 2010
6 August 1950 to 5 September 1950	6 January 2011
6 September 1950 to 5 October 1950	6 March 2011
6 October 1950 to 5 November 1950	6 May 2011
6 November 1950 to 5 December 1950	6 July 2011
6 December 1950 to 5 January 1951	6 September 2011
6 January 1951 to 5 February 1951	6 November 2011
6 February 1951 to 5 March 1951	6 January 2012
6 March 1951 to 5 April 1951	6 March 2012
6 April 1951 to 5 May 1951	6 May 2012
6 May 1951 to 5 June 1951	6 July 2012
6 June 1951 to 5 July 1951	6 September 2012
6 July 1951 to 5 August 1951	6 November 2012
6 August 1951 to 5 September 1951	6 January 2013
6 September 1951 to 5 October 1951	6 March 2013
6 October 1951 to 5 November 1951	6 May 2013
6 November 1951 to 5 December 1951	6 July 2013
6 December 1951 to 5 January 1952	6 September 2013
6 January 1952 to 5 February 1952	6 November 2013
6 February 1952 to 5 March 1952	6 January 2014
6 March 1952 to 5 April 1952	6 March 2014
6 April 1952 to 5 May 1952	6 May 2014
6 May 1952 to 5 June 1952	6 July 2014
6 June 1952 to 5 July 1952	6 September 2014
6 July 1952 to 5 August 1952	6 November 2014
6 August 1952 to 5 September 1952	6 January 2015
6 September 1952 to 5 October 1952	6 March 2015
6 October 1952 to 5 November 1952	6 May 2015
6 November 1952 to 5 December 1952	6 July 2015
6 December 1952 to 5 January 1953	6 September 2015

continues overleaf

DATE OF BIRTH	DATE OF ELIGIBILITY FOR DIAMOND TRAVELCARD
on or before 5 April 1950	date of 60th birthday
6 January 1953 to 5 February 1953	6 November 2015
6 February 1953 to 5 March 1953	6 January 2016
6 March 1953 to 5 April 1953	6 March 2016
6 April 1953 to 5 May 1953	6 May 2016
6 May 1953 to 5 June 1953	6 July 2016
6 June 1953 to 5 July 1953	6 September 2016
6 July 1953 to 5 August 1953	6 November 2016
6 August 1953 to 5 September 1953	6 January 2017
6 September 1953 to 5 October 1953	6 March 2017
6 October 1953 to 5 November 1953	6 May 2017
6 November 1953 to 5 December 1953	6 July 2017
6 December 1953 to 5 January 1954	6 September 2017
6 January 1954 to 5 February 1954	6 November 2017
6 February 1954 to 5 March 1954	6 January 2018
6 March 1954 to 5 April 1954	6 March 2018
6 April 1954 to 5 May 1954	6 May 2018
6 May 1954 to 5 June 1954	6 July 2018
6 June 1954 to 5 July 1954	6 September 2018
6 July 1954 to 5 August 1954	6 November 2018
6 August 1954 to 5 September 1954	6 January 2019
6 September 1954 to 5 October 1954	6 March 2019
6 October 1954 to 5 November 1954	6 May 2019
6 November 1954 to 5 December 1954	6 July 2019
6 December 1954 to 5 January 1955	6 September 2019
6 January 1955 to 5 February 1955	6 November 2019
6 February 1955 to 5 March 1955	6 January 2020
6 March 1955 to 5 April 1955	6 March 2020
6 April 1955 and later	date of 65th birthday

Office use only	BCC Tenant	<input type="checkbox"/>	Birth/Adoption Certificate	<input type="checkbox"/>
	Council Tax	<input type="checkbox"/>	Valid Photo Driving Licence	<input type="checkbox"/>
	Electoral Reg	<input type="checkbox"/>	Current Passport/EU ID	<input type="checkbox"/>
	Current Ctax Bill	<input type="checkbox"/>	Other
	Current TV Licence	<input type="checkbox"/>	CSP/Dept Verified

Personal Details

Title Mr Mrs Miss Ms Other

Surname

Previous surname(s)

Forename

Middle name(s)

Home Telephone No.

Work Telephone No.

Mobile Telephone No.

Gender Male Female

Date of Birth
 D D M M Y Y Y Y

Email address

Preferred contact method Telephone Letter Email
 Large Text Braille In person

Address

.....

.....

.....

Postcode

Previous address, if you have moved in the last three years

.....

.....

.....

Postcode

All New Applicants

a) Confirmation of address

Please answer **ONE** of the following questions, permitting us to check your address from information we already have for you, from our tenant or council tax records. *(This service is not available for postal applications).*

Are you a Bristol City Council tenant? Yes No

Are you paying Bristol City Council tax? Yes No

Office use only	
Anite checked	<input type="checkbox"/>
Iworld checked	<input type="checkbox"/>

OR

Provide ONE of the following as proof that you live within the city council boundary.

Valid Photo Driving Licence

Current Domestic Council Tax Bill

Current TV Licence

b) Is the address provided your sole or principal residence? Yes No

c) Confirmation of identity

Birth / Adoption Certificate

Valid **Photo** Driving Licence

Current Passport / EU identity card (mandatory for Non-British nationals)

Please supply ONE of these documents to confirm your identity.

Photograph

Please enclose ONE passport-style photograph of the applicant taken within the last three months even if you are renewing your card as we are unable to use existing Travelcard photos.

Please attach photograph here with glue.
--

Please note: Please follow guidance overleaf in order to provide an acceptable photograph (an unacceptable photograph will be refused, which will delay the production of your Travelcard).

Photograph

The following guidance should help you send us an acceptable photograph, you can get your photograph from a photo booth, or a professional photographer. If you have a problem getting a photo, please call us on **0117 922 2600** for advice.

Please supply a recent colour passport photograph.

It must be:

- Taken within the last three months.
- Standard passport size
45mm high x 35mm wide (millimetres).
- Taken against a pale background.
- You facing forward, looking straight towards the camera.
- Without any head covering, unless it is worn for religious beliefs or medical reasons.
- Nothing covering your face. Please make sure nothing covers the outline of your eyes, nose or mouth.

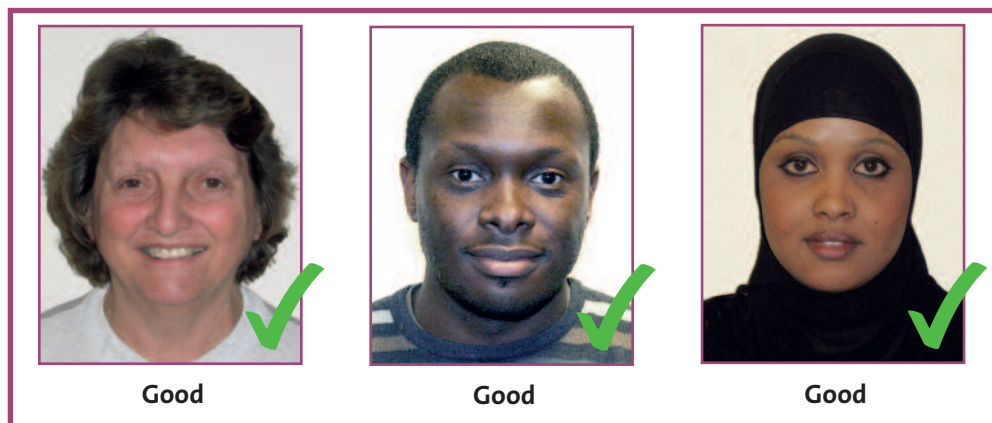
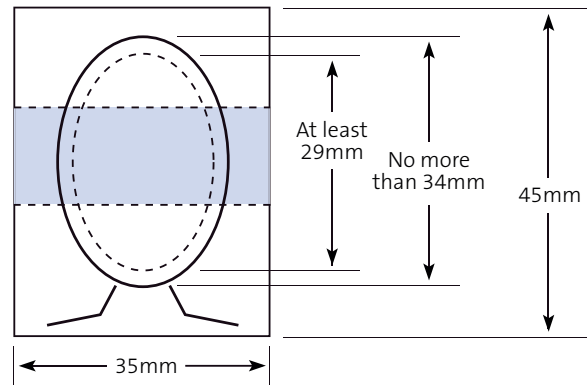

Application for a companion travelcard

The companion is a local enhancement in Bristol and does not extend nationally.

People who due to a disability are unable to travel on public transport without the aid of a companion for the duration of the journey, are eligible for a Travelcard with a companion entitlement.

The applicant must be unable to walk to a bus stop, get on or off a bus without assistance. Where a companion entitlement is granted, the companion must accompany the applicant for the whole of the journey and alight with them.

This section must be completed by a **General Practitioner** or **Consultant** and is only required when applying for a companion entitlement.

Please provide details of the applicant's disability and why the applicant requires a companion to be able to travel.

.....
.....
.....
.....

Name and position of Doctor/Consultant

Address

.....
.....
.....

Postcode

Telephone

Signature

Practice Stamp:

Declaration (to be completed by all applicants)

I declare to the best of my knowledge, all the information I have provided is correct.

I understand that I must promptly inform Bristol City Council of any changes that may affect my entitlement to a Travelcard.

I understand that Bristol City Council may contact an accredited health professional if necessary, for the purpose of obtaining information to support my application, for a companion entitlement.

You will, as the applicant for a Travelcard have to pay any cost incurred in providing a photo, posting your application or obtaining medical information, as the Council does not receive funding for this from the Department for Transport. The Council receives funding for the issuing of an applicant's first and renewal Travelcard and to administer the Concessionary Travelcard scheme.

Information provided may also be made available to other City Council Departments for the benefit of the client; this should assist in speeding up your application and to assess whether you have a right to other services provided by the Council.

Information provided will also be shared where there are lawful requirements to share information with external organisations and with other internal services/sections.

The Council is under a duty to protect the public funds it administers, and to this end may use the information you have provided on this form for the prevention and detection of fraud. It may also share this information with other bodies responsible for auditing or administering public funds for these purposes. For further information see www.bristol.gov.uk/nfi or contact the Concessionary Travel card Team on 0117 922 2600.

Signature

Date

Printed name

If you would like to know more about, how, why, when we share your information, or receive a copy of the information that we hold on you please write to:

Travelcard Office,
Bristol City Council,
PO Box 375,
Bristol, BS99 7GX

What to do now

Take this application form to one of our Customer Service Points, where original documents can be verified and your application form checked. Information on our Customer Service Points can be found at our website www.bristol.gov.uk/buspass or by telephoning **0117 922 2600**.

OR

If required the application can be sent to the following address with the original evidence and a recent photograph. Documents will be returned by recorded delivery.

Travelcard Office
Bristol City Council
PO Box 375
Bristol
BS99 7GX

Scheme information

The All England scheme provides free local bus travel throughout England between 0930 and 2300 on Monday to Friday and any time at the weekend and Bank Holidays.

If your journey begins within Bristol, Bath & North East Somerset, North Somerset or South Gloucestershire you can travel from 0900 until 0600 (following day) on Monday to Friday and at any time at the weekend and Bank Holidays.

Travelcards are accepted on all local bus services, Park & Ride services, all Bristol community transport services and the Bristol International Airport Flyer.

Travelcards are not accepted on long distance coach services, rail services or open-top tours.

Lost or stolen cards

If you lose or damage your Travelcard, a replacement can be issued for a fee. This charge reflects the actual cost of producing a replacement. If your Travelcard is stolen and you are able to obtain a crime reference number then a replacement will be issued free of charge. Please do not complete this form, you will need to obtain a replacement Travelcard form by either calling **0117 922 2600**, from one of our Customer Service Points, or by printing from the City Council Website at www.bristol.gov.uk/buspass

Blue Badges

If you are disabled, you may be eligible for a Blue Badge. Information on the Blue Badge scheme is available from our Customer Service Points or contacting **0117 922 2600**.

Equalities Questionnaire

Equalities Monitoring

We would be grateful if you could complete this equalities monitoring data sheet. This will help us to understand which groups and communities we have reached and those groups and communities of interest that have not responded.

Information on individuals will not be linked to named correspondence information and will be held as summary data only.

About yourself - Please tick as appropriate.

Race & Ethnicity

- White – British
- White – Irish
- White – Other European
- Mixed – White and Black Caribbean
- Mixed – White and Black African
- Mixed - White and Asian
- Asian or Asian British – Indian
- Asian or Asian British – Pakistani
- Asian or Asian British – Bangladeshi
- Black or Black British – Caribbean
- Black or Black British – African
- Black or Black British – African Somalian
- Chinese
- South East Asian
- Irish Traveller
- Roma Gypsy/Traveller
- Any other background:

Age

- 16 - 24
- 25 - 49
- 50 - 64
- 65+

Disabled

- Yes
- No

Religion & Belief

- Christian
- Muslim
- Hindu
- Sikh
- Jewish
- Other:
- None

Gender

- Male
- Female

Sexual orientation

- Lesbian, gay, bisexual
- Heterosexual

Transgender

- Yes
- No

**If you would like this information in a different format, for example Braille, audio CD, large print, electronic, BSL DVD or community languages, please contact:
The Council Concessionary Travel line on: 0117 922 2600**

