



All England Concessionary Travel Scheme

New or Renewal Application Form for a Disabled Person

This form together with original documents supporting your application, can be taken to any of our Customer Service Points. If you are unable to submit your application in person, please post the form and original documents to the address provided. These will be returned by recorded delivery.

Renewals only - Current Travelcard information

Travelcard number

Expiry date
of Travelcard
D D M M Y Y Y Y

All New and Renewal Applicants

a) Confirmation of address

Please answer **one** of the following questions, permitting us to check your address from information we already have for you, from our tenant or council tax records. *(This service is not available for postal applications).*

Are you a Bristol City Council tenant? Yes No

Are you paying Bristol City Council tax? Yes No

Office use only	
Anite checked	<input type="checkbox"/>
Iworld checked	<input type="checkbox"/>

OR

Provide **ONE** of the following as proof that you live within the city council boundary.

Valid Photo Driving Licence

Current Domestic Council Tax Bill

Current TV Licence

b) Is the address provided your sole or principal residence? Yes No

c) Confirmation of identity Birth / Adoption Certificate
 Valid **Photo** Driving Licence
 Current Passport / EU identity card (mandatory for Non-British nationals)

Please supply **ONE** of these documents to confirm your identity.

Photograph

Please enclose **ONE** passport-style photograph of the applicant taken within the last three months even if you are renewing your card as Bristol City Council cannot use previous Travelcard photos.

Please note: Please follow guidance overleaf in order to provide an acceptable photograph (an unacceptable photograph will be refused, which will delay the production of your Travelcard).

Please attach photograph here with glue.
--

Photograph

The following guidance should help you send us an acceptable photograph, you can get your photograph from a photo booth, or a professional photographer. If you have a problem getting a photo, please call us on **0117 922 2600** for advice.

Please supply a recent colour passport photograph.

It must be:

- Taken within the last three months.
- Standard passport size
45mm high x 35mm wide (millimetres).
- Taken against a pale background.
- You facing forward, looking straight towards the camera.
- Without any head covering, unless it is worn for religious beliefs or medical reasons.
- Nothing covering your face. Please make sure nothing covers the outline of your eyes, nose or mouth.

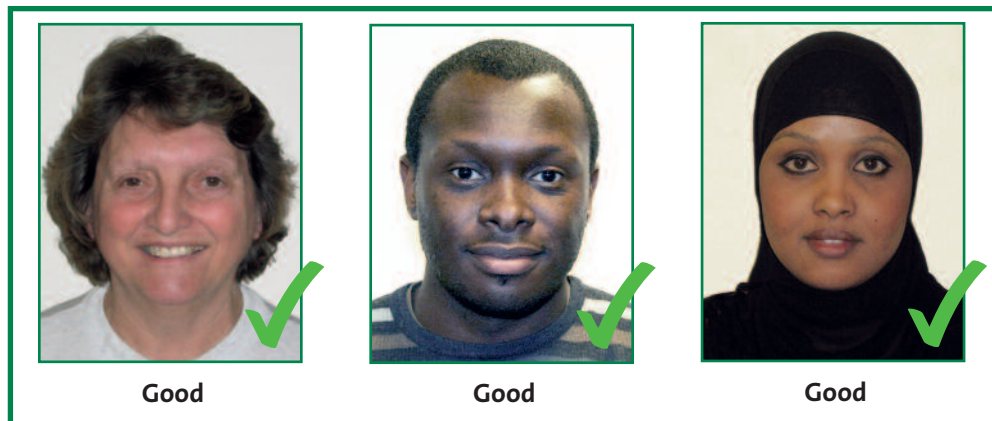
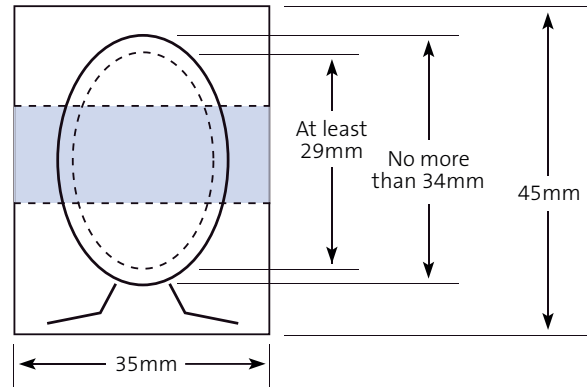

Which category applies to you?

In order to receive a Travelcard you must prove eligibility under one of the following Disability categories.

1. I am registered Blind or Partially Sighted.

Category A

Please note: If you meet the above criteria you will be issued a Platinum Travelcard, a large print application form is available by calling 0117 922 2600 or from our Customer Service Points.

Are you registered as Severely Sight Impaired (blind) or Sight Impaired (Partially Sighted) under the National Assistance Act 1948? Yes No

If Yes please supply your registration card.

Registration Card Number

Please supply contact details of the place where you were registered i.e. Bristol Eye Hospital

.....
.....
.....

I am Blind or Partially Sighted but not registered.

A person can be registered as Severely Sight Impaired (blind) if they cannot see (with glasses if worn) the top letter of the eye test chart (used by doctors and opticians) at a distance of three metres or less.

A person can be registered as Sight Impaired (partially sighted) if they have a full field of vision but can only read the top letter of the eye test chart at a distance of 6 metres or less (with glasses if worn).

Advice on how to register can be found on the Royal National Institute for the blind (rnib) website at www.rnib.org.uk

Are you blind or partially sighted but not registered? Yes No

To aid your application please provide contact details of your Ophthalmologist or General Practitioner so that we can confirm that you fulfil the above criteria.

2. I am profoundly or severely deaf.

Category B

Hearing loss is measured in decibels, dBHL (hearing level). People are generally regarded as having a severe hearing loss if it reaches 70-95 dBHL and a profound hearing loss if it reaches 95+ dBHL.

Are you profoundly or severely deaf? Yes No

3. I am without speech.

Category C

Persons considered to be without speech are those who are unable to make clear or basic oral requests (e.g. to ask for a particular destination or fare) – Unable to ask specific questions to clarify instructions e.g. ‘does this bus go to the High street?’ This does not include persons whose speech may be slow or difficult to understand because, for example of a stammer, or persons for whom English is not their first language.

Are you unable to speak or is your ability to speak severely and permanently impaired? Yes No

4. I have a disability, or have suffered an injury, which has a substantial or long-term effect on my ability to walk.

Category D

Please note:

- In order to be eligible you must receive the Higher Rate Mobility Component of the Disability Living Allowance, if you receive Middle or Lower Rate only, you are not eligible.
- If this award is for less than 12 months you will not qualify under this criteria.

Do you receive the Higher Rate Mobility Component of the Disability Living Allowance ? Yes No

Period of Higher Rate Mobility Component of the Disability Living Allowance Award

Start date until

D D M M Y Y Y Y D D M M Y Y Y Y

OR indefinite (tick box) OR for life (tick box)

Have you ever applied for the Higher Rate Mobility Component of the Disability Living Allowance and been refused? Yes No

If you do receive Higher Rate Mobility Component of Disability Living Allowance please provide recent evidence, no older than 12 months e.g. **original** official letter confirming award of the Higher Rate Mobility Component of the Disability Living Allowance.

Please note:

If your disability is severe but you have not applied for the Higher Rate Mobility Component of the Disability Living Allowance you may still be eligible for a Travelcard. If your ability to walk is severely restricted and you feel that if you were to apply for the Higher Rate Mobility Component of the Disability Living Allowance it would be awarded, please give medical details including a diagnosis of your condition on page 11 and provide recent medical evidence (for example, a letter or report from a specialist) to support your application.

Do you receive War Pensioners' Mobility Supplement? Yes No

Period of War Pensioners' Mobility Supplement Award.

Start date until
D D M M Y Y Y Y D D M M Y Y Y Y

OR indefinite (tick box) **OR** for life (tick box)

If YES please provide **original** official letter confirming award of War Pensioners Mobility Supplement, showing period awarded.

5. I do not have arms or have long-term loss of the use of both arms.

Category E

Persons who have a long-term inability to use both arms. These include upper limb double amputees and those with congenital absence of both upper limbs.

a) Do you meet these criteria? Yes No

If yes, please give details below.

.....
.....
.....
.....

6. I have a Significant Learning Disability.

Category F

A significant learning disability is a state of arrested or incomplete development of mind, which includes significant impairment of intelligence and social functioning. The person will have a reduced ability to understand new or complex information, a difficulty in learning new skills, and may not be able to cope independently. These disabilities must have started before adulthood and have a lasting effect on development and would have the same meaning as the previously used term, Mental Handicap.

Do you have a significant learning disability? Yes No

Do you hold a current provisional or full driving licence? Yes No

7. I am unable to drive due to a medical condition

Category G

Persons over 16 years of age, who on medical grounds have been, or would be refused a driving licence, OR have had their licence revoked are entitled to concessionary travel. Persons who hold a current provisional or full driving licence for group 1 or 2 vehicles will not be eligible for a Travelcard under this category (Please refer to the DVLA website for further information www.dvla.gov.uk). Persons who persistently misuse or abuse drugs or alcohol are NOT covered under this scheme and are NOT entitled to concessionary travel.

Please select the relevant medical condition that prevents you holding a driving licence:
Please tick the appropriate box(es).

- i) **Epilepsy** (unless it is a type that does not pose a danger) - please refer to DVLA guidelines for further information
- ii) **Severe mental disorder**
- iii) **Liability to sudden attacks of giddiness and fainting** (whether as a result of cardiac disorder or otherwise)
- iv) **Restricted visual fields** (who will be refused a licence if they do not have a horizontal field of vision of at least 120 degrees, or if they have a significant scotoma encroaching within 20 degrees of the central fixation point in any meridian, or sometimes, if they have restricted fields of vision)
- v) **Other disabilities** (another disability which is likely to cause the driving of a vehicle by them to be a source of danger to the public e.g. cardiac, locomotor, renal or neurological disorder)

Please note that these questions must be answered to be eligible under this medical category:

Do you hold a current provisional or full driving licence? Yes No

Is this licence currently revoked? Yes No

If yes, when can you reapply?
D D M M Y Y Y Y

Have you ever applied for and been refused a driving licence on medical grounds?

Yes No

If applicable you must provide the letter from the DVLA confirming your licence has been revoked.

Medical Information

Please provide as much information as possible. This will ensure that any required checks are carried out quickly and with the correct Consultant/Specialist Doctor.

Please provide us with details of the person you see in connection with your illness or disability? (preferably a person you have seen in the last 12 months).

For example, a Hospital Doctor or Consultant, District or Specialist Nurse, Community Psychiatric Nurse, Physiotherapist or Audiologist. Please tell us the professional address where you see them, such as health centre or hospital.

Their name

Their profession or specialist area

The address where you see them or their correspondence address
(whichever is appropriate):

Address

Postcode

Their telephone number
(Including the dialling codes)

Your hospital record number
(You can find this on your appointment letter or card)

Which illness or disability do you see them for?
.....

When did you last see them because of your illness or disability?
.....

If you have seen more than one health professional, please provide their contact details, treatment provided and the date of your last visit.
.....
.....

Application for a companion travelcard

People who due to a disability are unable to travel on public transport without the aid of a companion for the duration of the journey, are eligible for a Travelcard with a companion entitlement.

Children under 11 cannot apply for a companion Travelcard.

The companion is a local enhancement in Bristol and does not extend nationally.

The applicant must be unable to walk to a bus stop, get on or off a bus without assistance. Where a companion entitlement is granted, the companion must accompany the applicant for the whole of the journey and alight with them.

This section must be completed by a **General Practitioner or Consultant** and is only required when applying for a companion entitlement.

Please provide details of the applicant's disability and why the applicant requires a companion to be able to travel.

.....
.....
.....
.....

Name and position of Doctor/Consultant

Address

.....

.....

.....

Postcode

Telephone

Signature

Practice Stamp:

Declaration (to be completed by all applicants)

I declare to the best of my knowledge, all the information I have provided is correct.

I understand that I must promptly inform Bristol City Council of any changes that may affect my entitlement to a Travelcard.

I understand that Bristol City Council may contact an accredited health professional if necessary, for the purpose of obtaining information to support my application.

You will, as the applicant for a Travelcard have to pay any cost incurred in providing a photo, posting your application or obtaining medical information, as the Council does not receive funding for this from the Department for Transport. The Council receives funding for the issuing of an applicant's first and renewal Travelcard and to administer the Concessionary Travelcard scheme.

Information provided may also be made available to other City Council Departments for the benefit of the client; this should assist in speeding up your application and to assess whether you have a right to other services provided by the Council.

Information provided will also be shared where there are lawful requirements to share information with external organisations and with other internal services/sections.

The Council is under a duty to protect the public funds it administers, and to this end may use the information you have provided on this form for the prevention and detection of fraud. It may also share this information with other bodies responsible for auditing or administering public funds for these purposes. For further information see www.bristol.gov.uk/nfi or contact the Concessionary Travel card Team on 0117 922 2600.

Signature

Date

Printed name

If you would like to know more about, how, why, when we share your information, or receive a copy of the information that we hold on you please write to
Travel Office, Bristol City Council, PO BOX 375, Bristol, BS99 7GX.

What to do now

Take this application form to one of our Customer Service Points, where original documents can be verified and your application form checked. Information on our Customer Service Points can be found at our website www.bristol.gov.uk/buspass or by telephoning **0117 922 2600**.

OR

If required the application can be sent to the following address with the original evidence and a recent photograph. Documents will be returned by recorded delivery.

Travelcard Office
Bristol City Council
PO Box 375
Bristol
BS99 7GX

Scheme information

The All England scheme provides free local bus travel throughout England between 0930 and 2300 on Monday to Friday and any time at the weekend and Bank Holidays.

If your journey begins within Bristol, Bath & North East Somerset, North Somerset or South Gloucestershire you can travel from 0900 until 0600 (following day) on Monday to Friday and at any time at the weekend and Bank Holidays.

Travelcards are accepted on all local bus services, Park & Ride services, all Bristol community transport services and the Bristol International Airport Flyer.

Travelcards are not accepted on long distance coach services, rail services or open-top tours.

Lost or stolen cards

If you lose or damage your Travelcard, a replacement can be issued for a fee. This charge reflects the actual cost of producing a replacement. If your Travelcard is stolen and you are able to obtain a crime reference number then a replacement will be issued free of charge. Please do not complete this form, you will need to obtain a replacement Travelcard form by either calling **0117 922 2600**, from one of our Customer Service Points, or by printing from the City Council Website at www.bristol.gov.uk/buspass

Blue Badges

Under certain disability categories you may be eligible for a Blue Badge. Information on the Blue Badge Scheme is available from our Customer Service Points or by contacting **0117 922 2600**.

Equalities Questionnaire

Equalities Monitoring

We would be grateful if you could complete this equalities monitoring data sheet. This will help us to understand which groups and communities we have reached and those groups and communities of interest that have not responded.

Information on individuals will not be linked to named correspondence information and will be held as summary data only.

About yourself - Please tick as appropriate.

Race & Ethnicity

- White – British
- White – Irish
- White – Other European
- Mixed – White and Black Caribbean
- Mixed – White and Black African
- Mixed - White and Asian
- Asian or Asian British – Indian
- Asian or Asian British – Pakistani
- Asian or Asian British – Bangladeshi
- Black or Black British – Caribbean
- Black or Black British – African
- Black or Black British – African Somalian
- Chinese
- South East Asian
- Irish Traveller
- Roma Gypsy/Traveller
- Any other background:

Gender

- Male
- Female

Age

- 16 - 24
- 25 - 49
- 50 - 64
- 65+

Disabled

- Yes
- No

Religion & Belief

- Christian
- Muslim
- Hindu
- Sikh
- Jewish
- Other:
- None

Sexual orientation

- Lesbian, gay, bisexual
- Heterosexual

Transgender

- Yes
- No

**If you would like this information in a different format, for example Braille, audio CD, large print, electronic, BSL DVD or community languages, please contact:
The Council Concessionary Travel line on: 0117 922 2600**

