

**BRISTOL CITY COUNCIL**  
**PLACE DIRECTORATE**  
**APPLICATION TO DEPOSIT BUILDING MATERIALS**  
**(INCLUDING STORAGE CONTAINERS) ON THE HIGHWAY**  
 Highways Act 1980 S. 171



Please complete the following information and send the form to the address below allowing at least **2 WORKING DAYS** before you wish to make the deposit on the highway. Non-account holders should include the correct administration fee or make an on-line payment (see below). Licence/renewal fee **£62 PER CALENDAR MONTH**.

**Applicant**

Name ..... Tel No. ....  
 Address ..... Mobile No. ....  
 ..... Fax No. ....  
 Postcode ..... e-mail .....

I/We apply for permission to deposit the material listed below:

Description	Approx Qty	Description	Approx Qty

At (location) .....

And outside property number or name .....

In:  \*Road  \*Verge  \* Footway \*Delete as required

	From	To
Date		
Time		

And I agree to the conditions overleaf and to the special conditions given below:

.....(signature)  
 .....(date)

Permission IS NOT  Given for the deposit Because .....

IS  Subject to the conditions overleaf and the special conditions below:

**Special Conditions** (Tick if applicable or delete if not required)

- | Time | Date |
|------|------|
|      |      |
- The deposit may remain overnight and until (subject to condition 9)
- The deposit may only remain between 09.30 hours and 15.30 hours
- The deposit must be guarded by temporary traffic signals because the width of carriageway available is less than 5.5 metres
- Other

<b>Authorising Officer</b>	<b>By post to:</b> Bristol City Council – ABS Finance Team 1 Highway Licences (3C26) P.O Box 3176 Bristol BS1 9NE	<b>Email:</b> <a href="mailto:cd.highwaylicences@bristol.gov.uk">cd.highwaylicences@bristol.gov.uk</a> <b>Pay on-line:</b> <a href="http://www.bristol.gov.uk/pay">www.bristol.gov.uk/pay</a> <b>Tel:</b> 0117 922 2100
----------------------------	-------------------------------------------------------------------------------------------------------------------------------------	-------------------------------------------------------------------------------------------------------------------------------------------------------------------------------------------------------------------------------

APPLICATION DECISION

# Bristol City Council

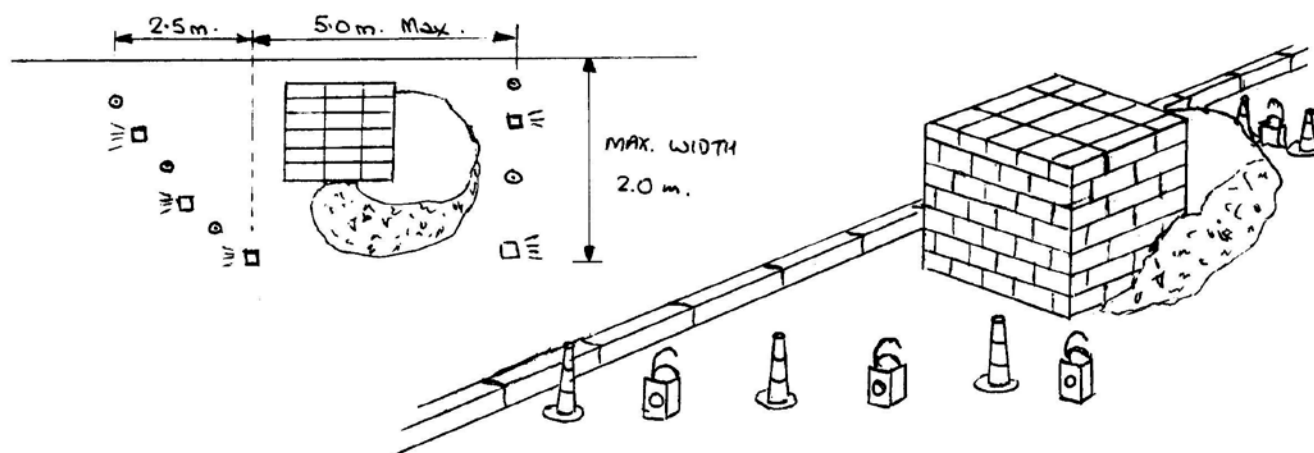

## DUTIES OF THE LICENSEE

### The licensee must:

1. Place and keep at least 5 traffic cones on the highway (see diagram) in day light for each deposit.
2. Keep any deposit under 5 metres long and 2 metres wide, minimum 15 metres between deposits.
3. Not block the channel or gutter; nor allow material to enter drains.
4. Not obstruct any gully drain or sewer chamber.
5. Not deposit any inflammable, explosive, or noxious material.
6. Not mix materials on the highway surface or allow material to enter any gully drain or sewer chamber (penalty £2,500 - see Section 170 Highways Act), but a mixing board may be used.
7. Clear the deposit by the time stated.
8. Sweep and removal all spillage and debris from the highway. And, if the deposit is authorised to remain overnight:
9. Place and maintain during lighting-up hours, a minimum of 5 lamps (minimum 1 candle-power each) for each deposit (see diagram).
10. Place and maintain warning signs as directed by the Highway Authority.
11. Immediately remove the deposit at the request of any Statutory Undertaker who requires the site.
12. Give a copy of this licence to the person receiving the materials.

### Penalty for non-observance

If the council has to take action to remedy a breach in these conditions or to repair damage the full costs shall be recovered from the licensee.

## **Legal Indemnity**

The licensee shall indemnify and save harmless Bristol City Council and/or its servants and agents against and from all claim demands actions costs and damages however arising out of, by or in consequence of, the depositing of materials on the carriageway, footway, or verge. The period of indemnity will run from the commencement of the deposit to the final removal of the same (the licensee's public liability insurance policy must be up to date and to £5 million limit).

## **Conditions to be observed by both supplier and owner of the deposit**

### **Materials shall not be deposited:**

- (i) Within 15 metres of any road junction.
- (ii) In any bus lane during its period of operation.
- (iii) During the hours of darkness unless specially authorised.
- (iv) Where parking restrictions or traffic measures are in force (unless specially authorised).
- (v) In major shopping areas and their access roads at, e.g. Christmas, sales, etc.
- (vi) Near public meeting places, e.g. churches, schools, football grounds, etc.

**If you would like this information in a different format, for example, Braille, audio CD, large print, electronic disc BSL DVD or community languages, please contact us on 0117 922 2100**



**PUBLIC LIABILITY INSURANCE RIDER FORM**

**Rider to conditions for:**

**Depositing Building Materials on Highway (Highways Act 1980 Section 171)**

I confirm that **PUBLIC LIABILITY INSURANCE** is held in the name of the applicant, as detailed below. I also confirm that the limit of insurance cover is to a minimum of £5 million, and that the insurance covers the period as detailed on the application. I understand that this requirement is in addition to the conditions and requirements detailed on the application.

Signed (name in block letters) .....

Position in Company .....

Name of Applicant .....

Date .....