

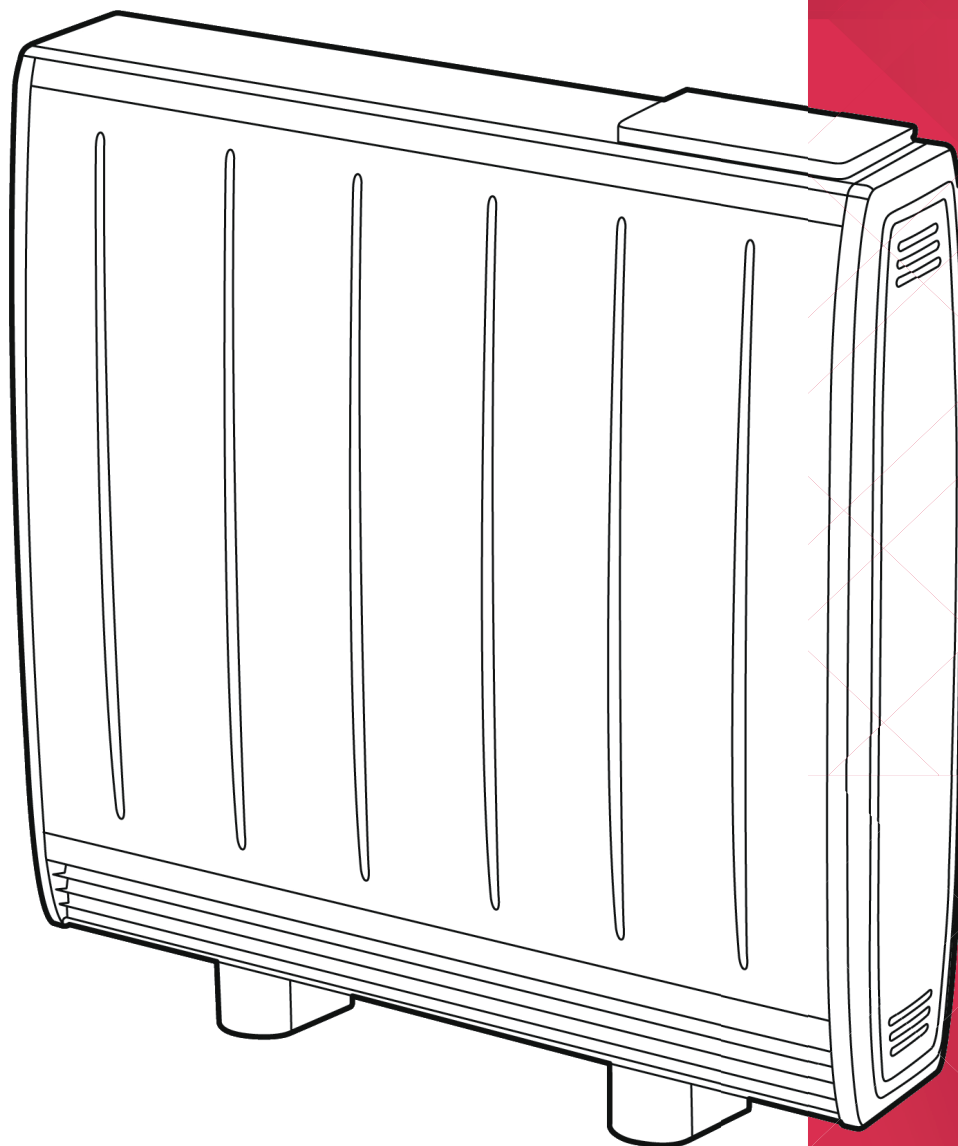

# INSTALLATION and OPERATING MANUAL



## Quantum Series Heater

Models: QM050RF / QM070RF / QM100RF  
QM125RF / QM150RF



## IMPORTANT

THESE INSTRUCTIONS SHOULD BE READ CAREFULLY AND RETAINED FOR FUTURE REFERENCE. Note also the information presented on the appliance



Warnings in this document are identified by a warning triangle against a grey background.

Keywords at the start of a warning indicate the type and seriousness of the ensuing risk if measures to prevent the risk are not taken.

The following keywords are defined and can be used in this document:

- **DANGER** indicates a hazardous situation which, if not avoided, will result in death or serious injury.
- **WARNING** indicates a hazardous situation which, if not avoided, could result in death or serious injury.
- **CAUTION** indicates a hazardous situation which, if not avoided, could result in minor to moderate injury.
- **NOTICE** is used to address practices not related to personal injury.

## CAUTION

FAILURE TO FOLLOW THESE INSTRUCTIONS MAY CAUSE INJURY AND/OR DAMAGE AND MAY INVALIDATE YOUR GUARANTEE

## IMPORTANT SAFETY ADVICE

When using electrical heaters, basic precautions should always be followed to reduce the risk of fire, electrical shock, and injury to persons, including the following:

**IMPORTANT** - The wall bracket supplied with the heater must be used.

**IMPORTANT** - All packaging should be disposed of in an appropriate manner.

## OVERHEATING WARNING

**WARNING** - In order to avoid overheating, do not cover or obstruct the heater. Do not place material or garments on the heater, or obstruct the air circulation around the heater, for instance by curtains or furniture, as this could cause overheating and a fire risk. NEVER cover or obstruct in any way the heat outlet slots at the top of the heater or the air outlet slots in the base of the heater.

## WARNING - THE SURFACES ON THIS HEATER CAN BE HOT.



The heater carries a warning 'DO NOT COVER' to alert the user to the risk of fire that exists if the heater is accidentally covered.

**CAUTION** - Some parts of this product can become very hot and cause burns. Particular attention has to be given where children and vulnerable people are present.

For your safety this heater is fitted with a thermal cut-out. In the event that the product overheats for some reason, the cut-out prevents excessive temperatures on the product by cutting the power to the heater. Once the heater has cooled down, it will reset automatically, it will continue to cycle on and off automatically until the reason for overheating is removed.

The display screen may flash red to indicate the product has overheated. To reset the display, remove the obstruction and hold **Enter** for 10 seconds.

## SUITABLE APPLICATIONS

**WARNING** - This heater is suitable for normal dwelling purposes and should not be used in any other type of environment. This product should only be used in the country where it was purchased from by a recognised commercial retailer. **Do not use outdoors.**

## SERVICING AND REPAIRS

**WARNING** - Servicing and product repairs should only be undertaken by the manufacturers approved service agent or a similarly trained or qualified person, using only exact manufacturer approved spare parts.

**PLEASE NOTE:** Household dust, lit cigarettes, candles and oil burners, combined with the convection effect of electric heaters can cause significant soot deposits to build up on the surface directly above and to the sides of the heater. This is not a fault of the heater. Extensive burning of candles or smoking in the operating environment of this product can produce heavy discolouration within a few months of use.

## OPERATING WARNINGS

**IMPORTANT:** Remember to observe all safety warnings and precautions when operating the heater on the automatic or timer modes, either attended or unattended since a fire risk exists when the heater is accidentally covered, obstructed or displaced.

**CAUTION:** Do not use if either of the heater's mains power leads become damaged. If the supply cord is damaged it must be replaced by the installer or an approved Dimplex service partner.

Do not sit or stand on the heater.

Ensure minimum clearances between the heater and other objects/surfaces are maintained.

## ELECTRICAL INSTALLATION

**WARNING** - Minimum clearances and IP zone requirements must be adhered to in accordance with the current wiring regulations.

Mains cables are not provided with this heater.

**WARNING** - The electrical installation of this heater must be carried out by a suitably qualified or trained electrician, and be in strict accordance with current wiring regulations. The peak supply must be connected via a switched fused spur with a fuse rated suitably for the appliances flex, the off-peak supply, via a 20A double pole isolated switch. In both instances a plug and socket arrangement **MUST NOT** be utilised. The contact separation to be a minimum of 3mm.

If the product is installed as a single supply (see page 8, 27 and 37 for more details), a 20A DP switch must be used as the supply is covering peak and off peak loads.

Failure to follow these instructions will mean that the manufacturer's instructions have not been adhered to. **THERE ARE NO EXCEPTIONS.**

- This heater must be earthed
- Not suitable for connection via a plug top
- Do not locate the heater immediately above, below or in front of a fixed electrical point i.e. socket outlet.

This appliance is intended for installation to a single phase supply only and is not suitable for connection to 3 phase supplies.

## ELECTRICAL INSTALLATION continued

The heater is not fitted with a mains cable, this should be fitted by the installer. Cable type (minimum size) H05VV-F 1.5mm<sup>2</sup> three core for peak and 2.5mm<sup>2</sup> three core for off-peak for connection to the fixed wiring of the premises through suitable isolation devices positioned adjacent to the heater. The supply circuits to the heater must incorporate a double pole isolating switch having a contact separation of at least 3mm. In installation the supply cord must be cut to the appropriate length for the electrical connection point. Excess cable should not be inserted or stored behind the heater.

If, during reassembly of the heater, a part of the thermal insulation shows damage or deterioration, it should be replaced by an identical part.

**WARNING:** All electrical connections to the terminal block must be secure to prevent risk of ignition. Tighten to Minimum torque of 2Nm and Maximum torque of 2.2Nm.

## CHILD SAFETY

**WARNING** - Fixing kit screws are a potential choking hazard.

**WARNING** - This appliance is not intended for use by persons (including children) with reduced physical, sensory or mental capabilities, or lack of experience and knowledge, unless they have been given supervision or instruction concerning use of appliance by a person responsible for their safety.

This appliance can be used by children from 8 years and above and persons with reduced physical, sensory or mental capabilities or lack of experience and knowledge if they have been given supervision or instruction concerning use of the appliance.

Children shall not play with the appliance.

Cleaning and user maintenance shall not be made by children without supervision.

Children of less than 3 years should be kept away unless continuously supervised.

Children aged from 3 years and less than 8 years shall only switch on/off the appliance provided that it has been placed or installed in its intended normal operating position and they have been given supervision or instruction concerning use of the appliance in a safe way and understand the hazards involved.

Children aged from 3 years and less than 8 years shall not regulate and clean the appliance or perform user maintenance.

**WARNING** - KEEP BATTERIES OUT OF REACH OF CHILDREN

**WARNING** - Packaging should be disposed of responsibly as the EPS used could be a potential choking hazard for children.



*This document is customer property and is to remain with this unit.*

*These instructions do not cover all the different variations of systems nor does it provide for every possible contingency to be met in connection with installation.*



### **WARNING: EARTHING**

This appliance must be earthed in accordance with the manufacturers recommendations and in accordance with IEE regulations for electrical equipment.

Failure to adequately earth the appliance can result in electrical shock causing severe personal injury or death.



### **WARNING: HAZARDOUS VOLTAGE**

Disconnect all power to unit before installing or servicing.

Hazardous voltage can cause severe personal injury or death.



### **WARNING: ACCESS TO LIVE PARTS**

If the supply cables to the appliance are damaged in anyway, they must be immediately replaced by a competent person in order to avoid electrocution which could cause severe personal injury or death.



### **WARNING**

The appliance must be securely fixed to the wall. The installed appliance could weigh up to 165kg and if it falls off the wall it could cause severe personal injury or death. It is the responsibility of the installer to ensure that the appropriate wall fixing is used and that the floor is capable of bearing the full weight.



### **WARNING**

To avoid a fire hazard the cardboard insert within the heater core must be removed before the heater is switched on. Also ensure all polystyrene packaging is removed before the heater is operated. Leaving combustible packaging in the appliance could lead to fire and cause severe personal injury, death and damage to property.



### **CAUTION**

The appliance is very heavy (up to 50kg) and care should be taken when handling during installation to reduce risk of muscular or skeletal injuries.



### **CAUTION**

The appliance should not be repeatedly switched on/off by an external room thermostat as this could lead to failures of the electronic controller and may invalidate the guarantee - further clarification SHOULD BE SOUGHT FROM <https://www.dimplex.co.uk/support>.



### **CAUTION**

During the first 48 hours of operation rooms must be well ventilated as the heater will produce a smell. Young children, caged birds, or persons with respiratory complaints must not remain in close proximity to the appliance during the first 48 hours of operation.



*It is important that the appliance bricks are dry and free from mould growth. Wet or mouldy bricks can lead to an unpleasant odour and or steam being generated by the appliance which could potentially be a hazard and could damage the appliance.*

## Energy Related Product Directive

This product meets the Ecodesign requirements for an electric storage local space heater. Commission Regulation (EU) 2015/1188.

Model Identifier(s):		QM050RF	QM070RF	QM100RF	QM125RF	QM150RF
<b>Heat Output</b>						
Nominal heat output	P <sub>nom</sub>	0.50kW	0.75kW	1.00kW	1.25kW	1.50kW
Minimum heat output (indicative)	P <sub>min</sub>	0.00	0.00	0.00	0.00	0.00
Maximum heat output	P <sub>max,c</sub>	0.90kW	1.20kW	1.50kW	1.70kW	2.00kW
<b>Auxiliary electricity consumption</b>						
At nominal heat output	el <sub>max</sub>	0.00	0.00	0.00	0.00	0.00
At minimum heat output	el <sub>min</sub>	0.00	0.00	0.00	0.00	0.00
In standby mode	e <sub>ISB</sub>	0.000	0.000	0.000	0.000	0.000
<b>Type of Heat input, for electronic storage local space heaters only</b>						
Fan assisted heat output	Yes					
<b>Type of heat output / room temperature control</b>						
Electronic room temperature control plus week timer	Yes					

### Contact details

Glen Dimplex Heating and Ventilation  
 Millbrook House, Grange Drive, Hedge End, Southampton, SO30 2DF  
 Tel: 0344 879 3588

This product meets the Ecodesign requirements for an electric storage local space heater. Commission Regulation (EU) 2015/1188.

## Technical Details

Model Identifier(s):	QM050RF	QM070RF	QM100RF	QM125RF	QM150RF
Input rating +5% / -10%	936/1020W	1435/1560W	2042/2220W	2540/2760W	3024/3300W
Rated Charge Period:	7.7 - 7 Hours	7.7 - 7 Hours	7.7 - 7 Hours	7.7 - 7 Hours	7.7 - 7 Hours
Fan Wattage	11W	11W	11W	11W	11W
Sound Level dB (measured in test chamber)	27	29	32	30	31
Height (mm)	730	730	730	730	730
Depth (mm)	185	185	185	185	185

All Models	
Controls	Digitally controlled, Electronic Thermostat accurate to ( $\pm 0.2^{\circ}\text{C}$ ).  <b>Timer modes:</b> 7 Day Programmable User Timer, Out All Day, Home All Day <b>Continuous heat modes:</b> Frost Protect <b>Additional Modes:</b> Away, Boost, Setback
Controller UI	<ul style="list-style-type: none"> <li>• Graphical display with RGB backlight</li> <li>• Tactile buttons with audio feedback</li> <li>• User replaceable battery (Coin-Type)</li> <li>• Open window detection, Adaptive Start, Advance Time Period</li> <li>• Wide SP range (<math>7\text{-}30^{\circ}\text{C}</math>)</li> <li>• Automatic Charge Control</li> <li>• History / Reporting Screens</li> <li>• Boost Mode, User Adjustable</li> <li>• Heat Demand % Adjustment</li> <li>• Child Lock &amp; Heater Lock (PIN-based)</li> </ul>
Safety	Electronic overheat protection. Additional electromechanical overheat protection. LVD and EMC compliance.
IP Rating	IPX4
Battery	3.3V coin cell battery to backup real time clock. Battery life > 5 years.
Supply	1/N/1/N/PE ~230-240V (Peak + Off Peak) 230-240V / 50Hz Class II
Colour / Finish	Traffic White (RAL 9016), Grille RAL7035
Storage Core	High-density bonded magnetite energy cells
Approvals	UKCA, CE & BEAB
Guarantee	2 Years. 10 Years extended available with registration.
Country of Origin	United Kingdom
Manufacturer	Glen Dimplex Heating & Ventilation (Glen Dimplex UK Ltd)

# Operating Instructions

## Product Clearances

 **WARNING:**  
**DO NOT PLACE OBJECTS  
WITHIN 300mm OF THE  
FRONT OF THE HEATER  
AND 150mm EITHER SIDE**

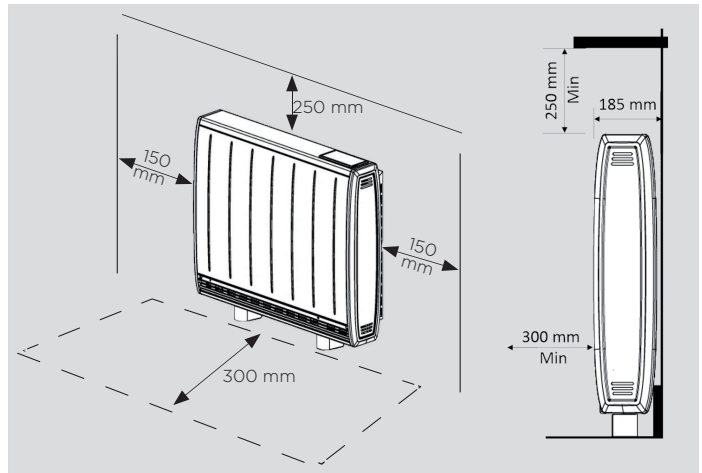

## Single Supply

It is important to be aware of how your Quantum storage heater has been installed electrically. If your Quantum has only one electrical connection, it must be carefully configured to work with your off-peak electricity tariff.

Available fixed charge times must be manually programmed into the heater to tell it when to charge; no external timers or contactors are needed. Up-to 4 digital charge times can be set.

If charge times are not programmed into the heater, the default times will be used which are set-up by default to support dual-supply installations: 00:00 - 00:00 or 24h charge window.



A 24h charge window in a single supply installation will cause the heater to charge continuously, including times when off-peak electricity is not available, resulting in larger bills.



### NOTE:

*If electricity tariff charge times have changed, the digital charge times in the heaters settings must be checked to ensure they match.*

## First Time Power-On

A setup wizard will display when the product is powered on for the first time. This will set the following:

- Time, Date, Daylight Savings Time
- Sound On/Off

For information on using the Heaters controls, refer to page 10. The Heater will then take the User to the Home Screen with the 'Out All Day' Timer Mode active.

### IMPORTANT

During initial heat-up, some odour may be emitted due to the newness of materials used in manufacture. This is normal and will disappear after a short period of use, It is however advisable to keep the room well ventilated

## Dimplex • Control

This product is Dimplex Control capable \* \*\*.

Control and monitor your heating and hot water with Dimplex Control. Group heaters into zones to easily control and track their energy usage. Any time. Anywhere.

Search for Dimplex Control on your device's app store.



*\*Requires additional hardware. Sold separately. Visit [Dimplex.co.uk](http://Dimplex.co.uk) for more information.*

*\*\*A Dimplex Hub is required for this product to connect to Dimplex Control. For instruction on setting up Dimplex Hub, please refer to the manual. Manuals can be downloaded at [Dimplex.co.uk](http://Dimplex.co.uk).*

# Operation

**WARNING: FAILURE TO FOLLOW THESE OPERATING INSTRUCTIONS MAY RESULT IN INJURY AND/OR DAMAGE**

The controls are located on the top of the heater consisting of a display screen and three buttons and a Dial.

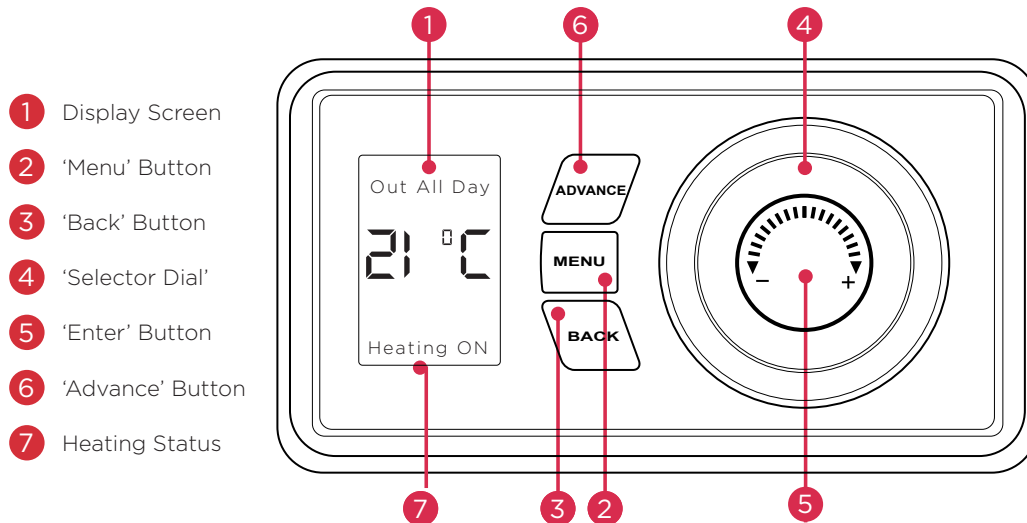

The heater is fitted with an adjustable thermostat enabling the room temperature to be controlled. The minimum room temperature is 7°C. The maximum temperature is set to 30°C by default. A temperature of 21°C is a common comfortable room temperature.



## NOTE:

*Your heater may produce some noise during operation. This noise is caused by the low noise fan and expansion and contraction of the metalwork as it changes temperature, and is normal for this type of product. Whilst the noise produced is usually very quiet, certain environmental factors can make it more noticeable, such as hard flooring or minimal furnishings.*



## NOTE:

*Should the heater fail to operate, this may be due to the room temperature being higher than the thermostat setting.*

The heater controls can be easily adjusted by using the Dial and buttons on the User Interface.

1. The Home Screen shows the options available at each stage of adjustment. Here the current target room temperature is displayed along with the mode of operation. Any use of the Advance function will be displayed here, and pressing the Dial will show the functions which are enabled.

The currently active mode of operation is displayed at the top of the screen e.g. 'Out All Day' timer.

When the heater is in a timer profile and trying to achieve or maintain a room temperature, 'Heating On' will be displayed, otherwise, 'Heating Off' will be displayed. The words 'Heating On / Off' will not be displayed in a manual mode of operation

When the controller buttons have not been pressed for a long period of time, the display will 'sleep' and the text will disappear. The heater is still on and active in whatever Mode it was set to.

2. **Menu** - Displays the Main Menu;
  - Boost - Activate Boost Mode
  - Modes - Set the mode of operation.
  - Settings - Time/Date, Temperature units etc.
3. **Back** returns to the previous screen.
4. Rotate the **Dial** to navigate through the menus and adjust the required room temperature on the main screen. The screen colour changes based on the temperature selected, showing deep blue through to bright red.
5. Press the **Dial** to enter sub menus and to confirm actions.
6. The **Advance** button is only used when a Timer Mode is active, it allows the timer schedule to be changed temporarily by forcing a 'Heating On' period to begin or end early.



# Settings

To navigate to the Settings Menu, from the Home Screen:

Press the **Menu** button to access the Main Menu. Rotate the **Dial** to highlight 'Settings', then press the **Dial**. Each of the following headings relate to an item in the Settings Menu.

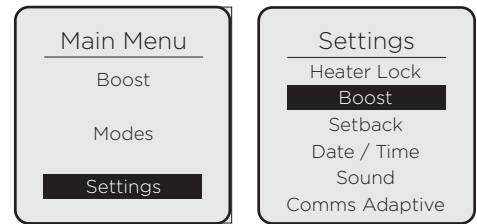

Heater Lock - see page 34.

## Boost Settings

### Default Boost Target Temperature

This is the default Boost Target Temperature that is used when 'Boost Mode' is activated.

### Max Boost Duration

This is the maximum length of time that the user is able to activate 'Boost' for. Shown in minutes (when under an hour) or hours (if over an hour) in the following increments: 30 mins, 1 hour, 2 hours, 3 hours, 4 hours.

The value chosen will be the max allowed when boost is activated. This is required for the Boost Duration Lock to function.

## Setback Settings

**Setback** is a function that only modifies Timer Mode operation. When Setback is enabled it overrides any 'Heating Off' period to maintain a constant temperature.

This can be used to prevent the room temperature from falling below a minimum value while there is no demand for heat ('Heating Off').

The value of this temperature is restricted to a value between 8 and 19 °C. This is because Setback should not be treated as a regular 'Heating On' period.

## Date & Time Settings

This allows the Time, Date and Daylight Savings Time settings to be modified.

## Sound Settings

Audio feedback when the user presses a button can be enabled or disabled here.

## 'Comms' (Communications) Settings

This allows Wireless Connectivity features to be enabled or disabled. Entering this menu item will display a list of available communications methods to that heater.

## Adaptive Settings

### Open Window Detection

This is a global setting that can interrupt any active mode. Activating this setting enables Open Window Detection to switch the Heater to a 'Heating Off' state if it detects an open window in the room it's operating in.

### Adaptive Start

Adaptive Start is predictive function that only modifies Timer Mode operation. This function models the heating characteristics of the room and uses that information to pre-heat the room for only the time required to achieve the Target Temperature by the start of the 'Heating On' period.

For example, with Adaptive Start off, the 'Heating On' time is the time that the Heater will begin to try and achieve the Target Temperature. With Adaptive Start On, the Heater will begin to heat the room before the User-defined Heating On time so that the Target Temperature is achieved when the User defined the 'Heating On' start time.



#### **NOTE: Adaptive Start**

*This is a continuously learning function and will be affected daily by changes in the heater's environment. The heater will take into account the starting temperature of the room so pre-heating should remain accurate.*

*It is important that if multiple heaters are installed in one room that all heaters have the Adaptive Start (AS) function enabled. If this is not the case, heaters with AS enabled will pre-heat the room to the desired target temperature before the heaters with AS disabled attempt to output heat.*

*It is likely that if two heaters are required in one room, that the output from one heater may not be sufficient to heat the room alone. This may cause the pre-heat time calculation to extend to a large degree if the heaters do not all have AS enabled. This may lead to heat at unwanted times and excessive wear to some heaters.*

*A two-hour limit is enforced on the calculation, however, if all heaters have AS enabled and pre-heating takes over one-hour, extreme environmental factors may be affecting the calculation or the heaters may be under sized for the room. Please contact us for support if your pre-heat time seems excessive.*



#### **NOTE: Open Window Detection**

*In environments where the product may read sudden decreases in temperature, this feature may activate in error. This can occur in drafty or poorly insulated environments as well as if the heater is undersized for the room. This feature should be disabled using the instructions above if activating for reasons other than the intended purpose. If you think that your environment is not as described here and this feature is activating, please contact our customer care team with the details on the rear page of this document.*

# Timer Modes

Timer Modes offer the most efficient mode of operation for a predictable heat demand. Additional functions such as Advance and Boost allow the User to make temporary adjustments to timer schedules for a more flexible operation.

Each timer is broken down into 4 definable 'Heating On' time periods and temperatures per day, for each day of the week. Each day consists of a 24-Hour period, starting and finishing at midnight.

When the heater is in a timer profile and trying to achieve or maintain a room temperature, 'Heating On' will be displayed. Otherwise, 'Heating Off' will be displayed.

It is possible to change the Target Temperature of a 'Heating On' period when that period is active. This will temporarily adjust the Target Temperature for just that instance and will not permanently modify the settings for the timer in use.

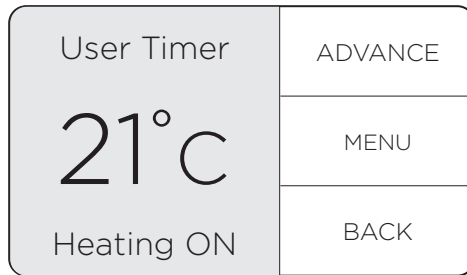

**NOTE:**

*If Adaptive Start is enabled, the heater will maintain the room at the required temperature for the duration of the heating period. To achieve this, the heater will begin heating the room before the start of the heating period to ensure the room is at the required temperature when the period starts.*

*If Adaptive Start (AS) is disabled, the heater will not operate until the beginning of the heating period. This should be taken into consideration when setting the heating periods.*

*See page 12 for instruction on enabling/disabling Adaptive Start.*

# Available Timer Modes

To choose a timer mode, press **Menu** from the home screen. Rotate the **Dial** to highlight 'Modes', then press **Dial** to select. 'Timer Mode' should be highlighted, press the **Dial** to select.

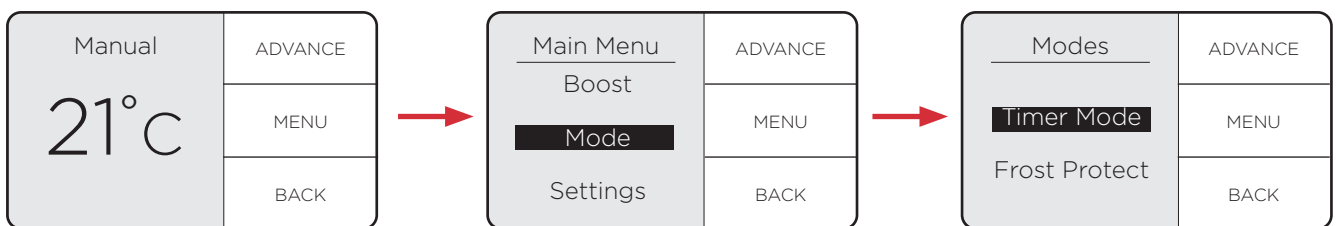

A list of Timer Modes will be shown. Their default settings are shown in the table below.

	Period 1		Period 2		Period 3		Period 4	
User Timer	06:30 - 09:30	21 °C	11:00 - 13:00	21 °C	15:00 - 17:00	21 °C	18:00 - 22:00	21 °C
Home All Day	08:00 - 21:00	21 °C	00:00 - 00:00		00:00 - 00:00		00:00 - 00:00	
Out All Day	07:00 - 8:30	21 °C	17:30 - 22:00	21 °C	00:00 - 00:00		00:00 - 00:00	
Away Mode	Away Mode does not operate in the same way as the other Timers. See section 'Away Mode' on page 15							

Highlight and select one of the available Timer Modes rotating and pressing the Dial.

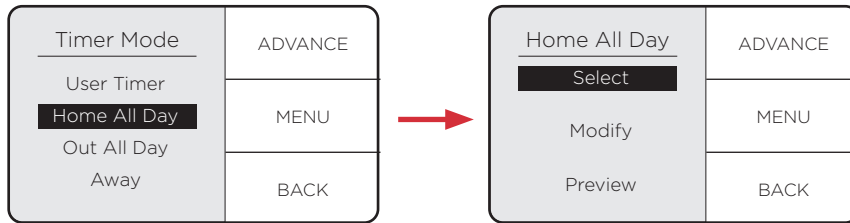

For User Timer, Home All Day and Out All Day, three choices will be available:

- Select - This option will activate the timer
- Modify - This option allows the timer's 'Heating On' times and Target Temperatures to be modified
- Preview - This option displays the timer's configuration. This is handy to quickly check the timer without being able to change any values

## Modifying a Timer Mode



### NOTE:

*Once modified a Timer Mode must be selected if you want to begin using it.*

Each timer is broken down into 4 definable 'Heating On' periods and temperatures per day. When Modify is chosen, 'Heating On' period 1 of 4 for the current day is displayed. The current day will be highlighted. Rotate dial to highlight 'Modify', press dial to select. The current day will be highlighted.

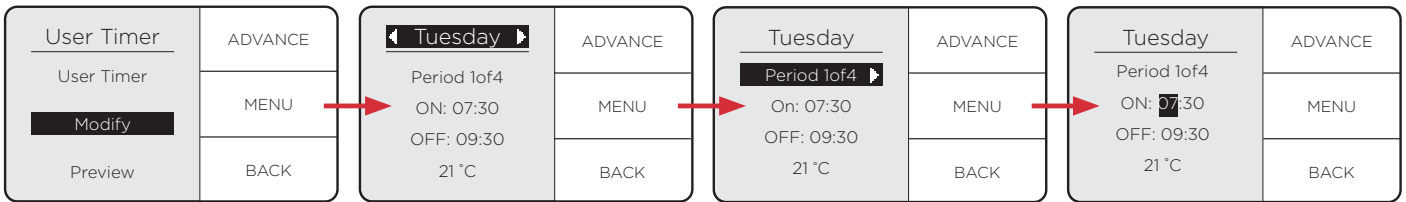

Select and change each option by rotating and pressing the dial.

## Copy & Paste

To save time when modifying a Timer Mode, the **Advance** button can be used to copy and paste settings. Individual heating periods from one day or every heating period from a day can be copied to another day.

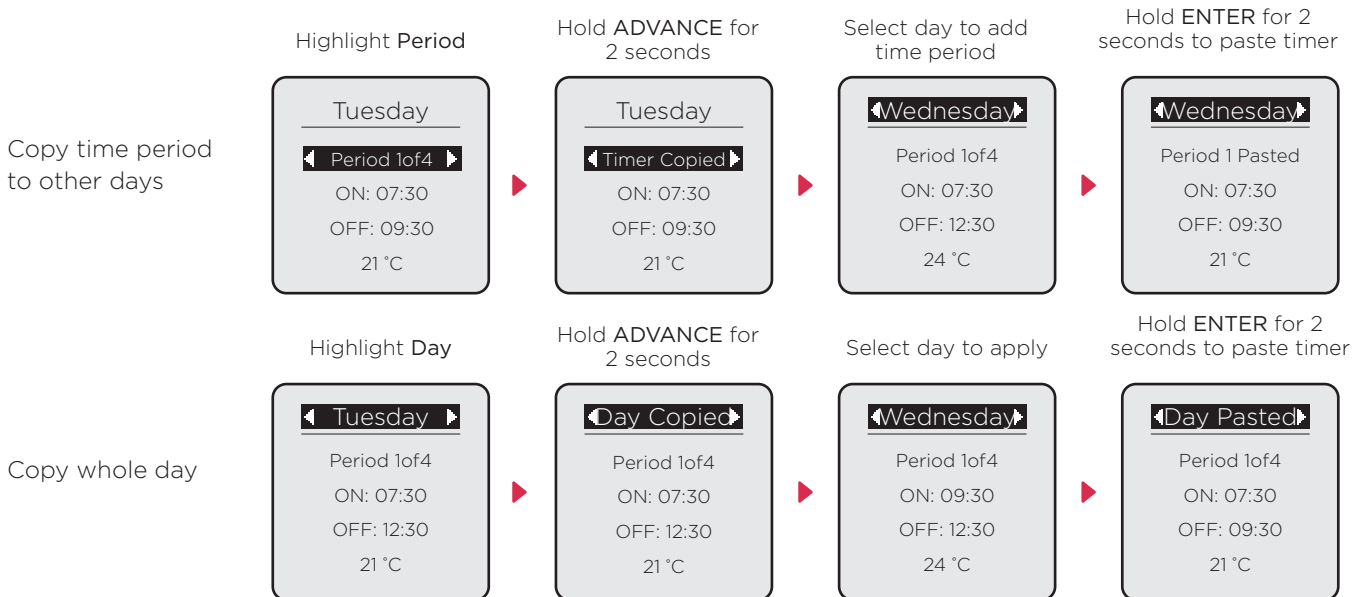

## The 'Advance' Function

The **Advance** button is only used when a Timer Mode is active and allows the timer schedule to be changed temporarily. This button allows a 'Heating On' period to begin or end early.

This is useful if you are at home when you had not planned to be, or need to leave when you had planned to have the heating on.

If the heater displays 'Heating Off' and heat is required, press the **Advance** button. If the heater is in 'Heating On' and heat is not required, press the **Advance** button and the heater will stop heating until the beginning of the next 'Heating On' period.

Pre-action State	Action	Impact
		Heating On period switched to Heating Off until next scheduled 'Comfort On' period.
Heating Off (Timer Mode)	Advance activated	Heating Off switched to Heating On until the next scheduled 'Heating Off' period.
	Advance Deactivated	Heating On switches to Heating Off. Appliance in following schedule set in the currently active Timer Profile
Heating Off (Advance Active)	Advance Deactivated	Heating Off Switches to Heating On. Appliance in following schedule set in the currently active Timer Profile

## Away Mode

Away Mode temporarily overrides the active mode before returning the Heater back to the previously active mode.

This is handy if you are temporarily away at the shops or on holiday and want your heating to resume as normal operation automatically when you return.

While active, Away Mode can maintain a minimum room temperature. By default, this is set to 7 °C (frost protection temperature). This can be modified up to a maximum of 18°C when Away Mode is activated. The heater will also remember the last Away Mode Target Temperature defined while Away Mode is active.

The Away countdown is set in Hours, a Date and a Target Temperature.

The starting Hours and Date show current time and date. Date and Hours are set separately on the heater, making the feature useful for popping out to the shops or going away on holiday.

- The date set is the return date; therefore, Away Mode will end at 23:59 of the day before. E.g. if a return date of 02.02.2018 is set, Away Mode will end at 23:59 on 01.02.2018.
  - If hours are set, this will extend away mode end from 23:59 on the day before the date set.
- If only hours and no date is set, Away Mode will count from either the current time, or if a date is set.

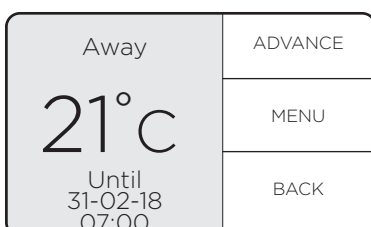
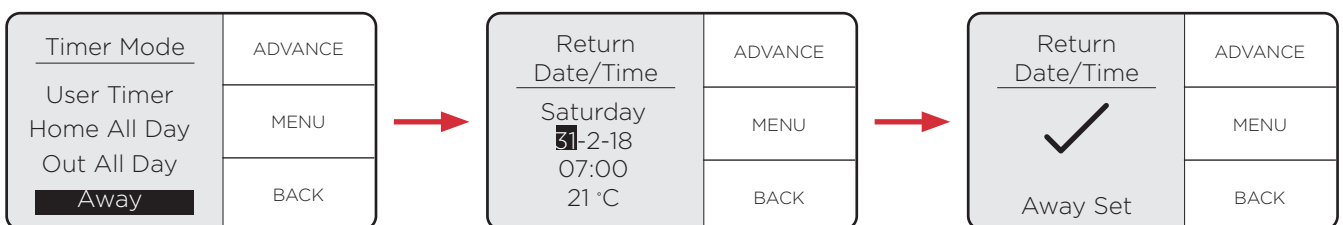

### NOTE:

The Back button can be used to end the Away Mode countdown early.

# Frost Protect

This mode maintains a room temperature of 7°C and should be used to provide protection against frost. The Heater will remain in this mode indefinitely until the mode is changed by the User.

To select Frost Protect, rotate **Dial** to highlight 'Frost Protect', press **Dial** to select. Please note, the temperature is not user definable.

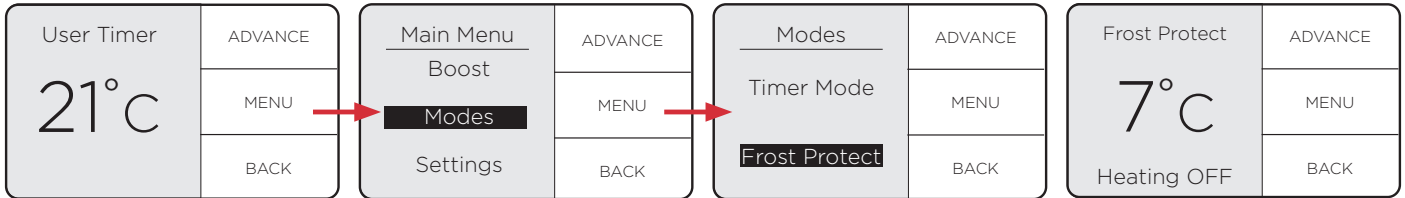

# Boost Mode

Boost can be activated at any time, when the product is set to any Timer or Continuous heat mode; even if Advance is active, this mode will provide a temporary 'Boost' of heat. For settings, see Boost settings on page 11.

Boost Mode can be activated from the Home Screen by pressing 'Menu' to access the Main Menu, then pressing the Dial to select 'Boost'. 'Boost' will always be listed as the top item on the list.

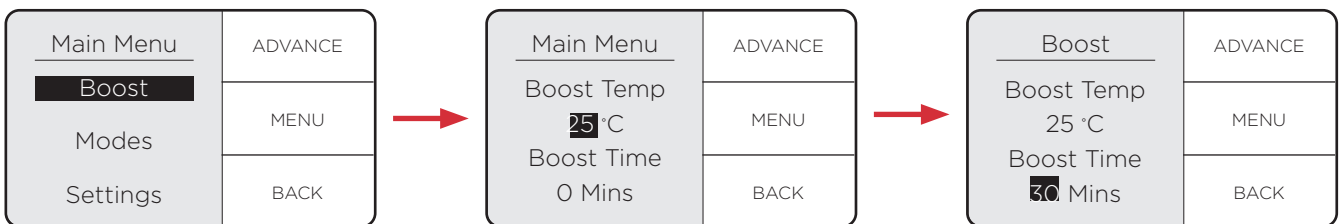

Activating Boost will present two selectable options: Boost Temp (Boost Target Temperature) and Boost Time (Boost Duration Countdown). The default values for these can be set in the Settings Menu.

Rotate and press the **Dial** to modify these values. Pressing **Back** will end Boost early, restoring the heater back to its previously active mode.

- The Boost Temp can be set to any value within the Heater's Target Temperature Range setting.
- The Boost Time can be increased in the following increments: 30 mins, 1 hour, 2 hours, 3 hours, 4 hours. These increments can be restricted with the Max. Boost Duration Range setting. To modify this range, see Boost Settings on page 11.

Once the Boost Duration Countdown has reached 0, the Heater will return to the mode that was active before Boost was activated.



**NOTE:**

*If boost mode is activated and there is not enough stored core energy, peak rate energy will be used unless disabled in heat source settings.*

# Product Locks

Product Locks are methods of locking the heater's controller to restrict access to functions. This can be activated and configured via the Settings Menu. When Product Lock is activated, the heater continues to run in whichever mode is currently active and any/all wireless communications remain active if enabled.

## Child Lock

This is the simplest locking method and does not utilise a PIN code. It is toggled on/off on the heater's controller by pressing and holding the **Back** button and the **Dial** for three seconds.

While Child Lock is active, the heater will continue to operate in whatever mode, with whatever settings it had before the lock was activated.

There are no exception rules with this lock, and the user can only choose to unlock the heater if they wish to change the temperature, modes or settings.

## Heater Lock (PIN Lock)

Heater Lock is the most customisable and secure lock on the heater. This allows the heater to be configured in any way, then locked into those settings and modes.

When PIN Lock is activated, pressing the **Menu** button will show one item\* that can be selected - 'Unlock'. Selecting 'Unlock' prompts the User to complete the applicable Unlock action:

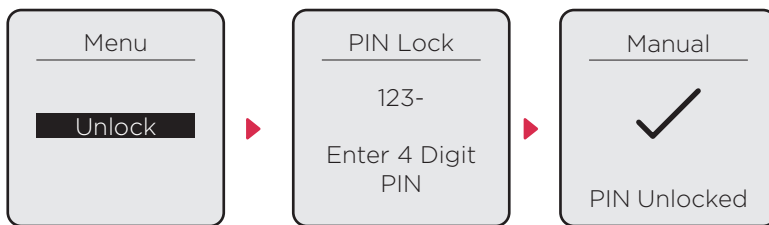

\*Unless Boost Mode has been enabled during UI Lock

## PIN Lock Exceptions

It is possible to allow the 'Advance' and 'Boost' functions to be enabled/disabled when PIN Lock is active. There are up to 4 exceptions. These exceptions include:

- **Advance**
  - Ability to activate using the 'Advance Button'
- **Boost**
  - Ability to activate using the 'hotkey' listed in the Main Menu
  - Ability to modify the Boost Temperature
  - Ability to modify the Boost Duration

## 'Advance Function' Operation during PIN Lock

If Advance has been enabled during PIN Lock, the Advance button will remain active when PIN Lock is active. This will function in the same way it would if the controls were not locked: only if the Heater is Locked into a Timer Mode.

- If Advance is enabled during UI lock, the **Advance** button will function as normal while the Heater is set to a Timer Mode.
- If Advance is Disabled during UI lock, the **Advance** button will not function.

## 'Boost Function' Operation during PIN Lock

If enabled, Boost will function in the same way as it does when PIN Lock is not active unless modification of Boost Temperature and Boost Duration have been disabled.

Boost Temperature and Boost Duration will be set to the default values when 'Boost' is activated. If either of these values have been disabled during Product lock, when the user tries to modify them the heater's display will show the message 'Disabled' and only the default value can be used. The default values can be changed outside of PIN Lock.

# Error Codes

Error codes are to be defined as a list. Each error code must be defined as a perimeter that Central Control can read.

Fault Code	Description
20	Component thermistor hardware fault
20	
21	
22	
23	
24	
30	Component overheat
32	
33	
34	
40	Internal serial comms error
41	Heating element fault
50	Open window detected
52	Heat output disabled
53	Time loss error
55	Unknown error
60	Wireless communication module error
61	Hub connection error



# Installation Instructions



Please scan the QR code to access detailed Quantum Installation Instructions. Included are a view of the product, how to unpack the unit, install exterior components, install internal components, securing to the wall, sizing and fitting instructions, electrical connections and set up.

## Preparation



### WARNING:

**DO NOT PLACE OBJECTS WITHIN 300mm OF THE FRONT OF THE HEATER AND 150mm EITHER SIDE**

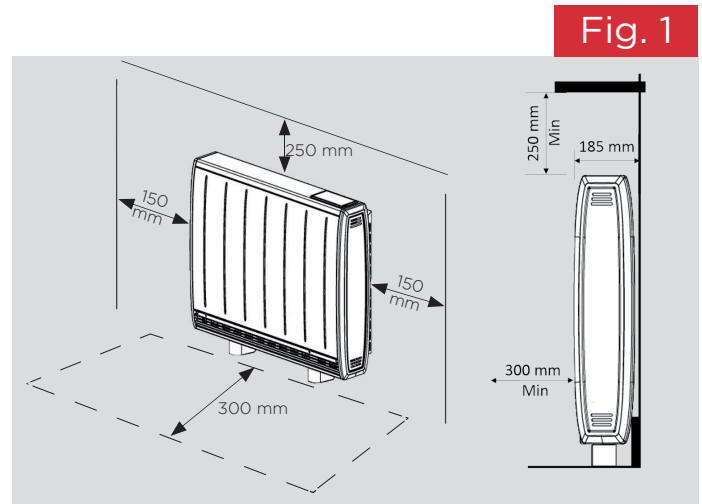
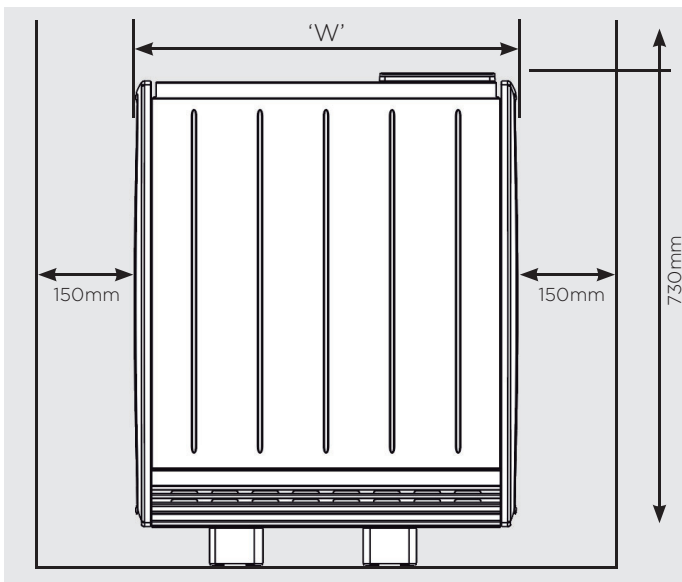

Fig. 1



Models	W (mm)
QM050RF	580
QM070RF	703
QM100RF	865
QM125RF	1069
QM150RF	1069

All Models	Foot Height
QMRF Feet	60mm

If required, there is an option to purchase a Tall Foot Accessory which is 140mm high.

Part Number 080479

Please contact your supplier for details.



### CAUTION

The appliance is very heavy (up to 50kg) and care should be taken when handling during installation to reduce risk of muscular or skeletal injuries.



**NOTE:**

*Read these instructions carefully before proceeding any further with the installation*

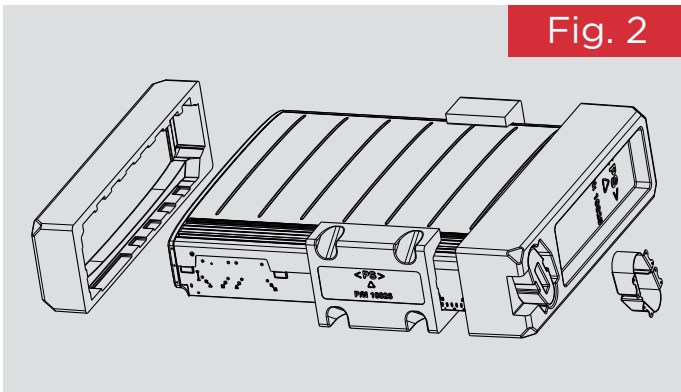

**CAUTION**

Do not use the outer top panel or the rear heat shield to lift or carry the heater.

1. Place the heater flat on the ground with arrows printed on the base of the carton pointing upwards.

Open the carton at the bottom, slide the heater out of the carton by at least 200mm exposing the feet and the fixing kit located within the packaging on the right hand side. Remove the feet and the fixing kit. (Fig. 2)

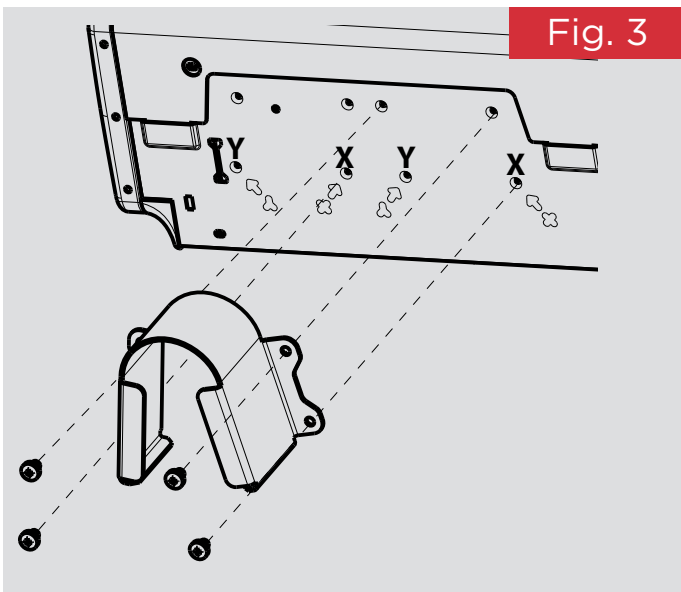

2. Secure the feet to the heater using all the screws provided (4 per heater). For models QM050, QM070 and QM100 two locations are possible indicated by X and Y markings visible on the base of the heater.

Ensure the feet are fixed at the location holes marked with an 'X', (Fig. 3/3B).

However, if this is a replacement heater check the pitch of the feet and choose the appropriate fixing positions - either X or Y.

Note - Foot screws are in the fixing kit.

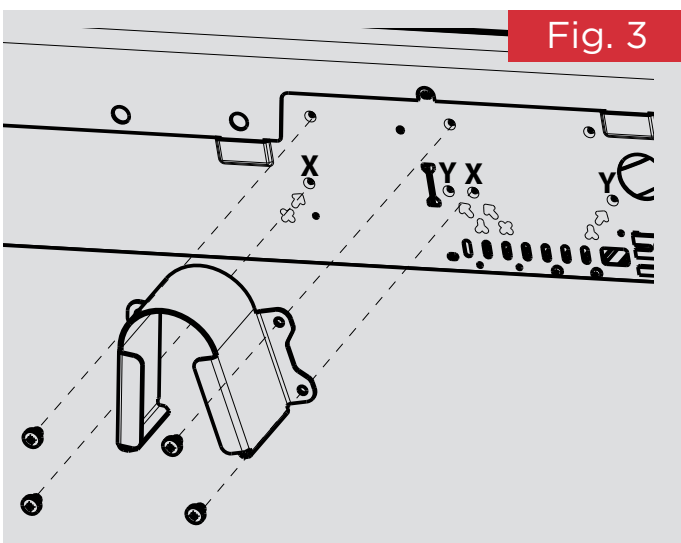

Models	LH Foot				RH Foot			
	X		Y		X		Y	
050	199	211	114	296	198	212	113	297
070	191	157	166	182	194	155	171	178
100	190	98	166	121	150	111	176	138
125 / 150	189	343	189	343	265	267	265	267

The Quantum feet can be fitted in two different locations (X and Y). The X and Y are stamped onto the base of the heater indicating the 2 locations

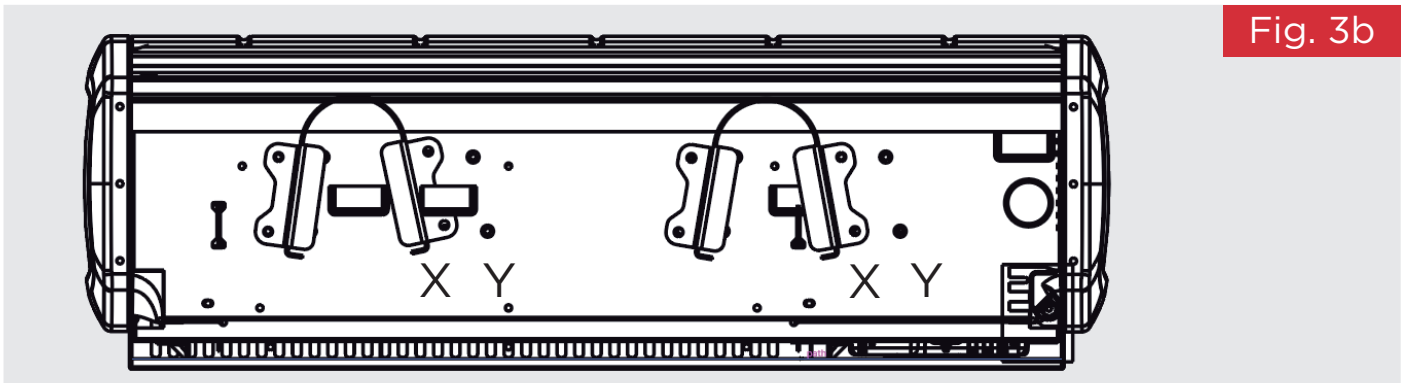

Fig. 3b

3. Remove the centre EPS piece and stand the heater on its feet before removing the packaging.

Dispose of the packaging in an appropriate way.



### WARNING

To avoid a fire hazard the cardboard insert within the heater core must be removed before the heater is switched on. Also ensure all polystyrene packaging is removed before the heater is operated. Leaving combustible packaging in the appliance could lead to fire and cause severe personal injury, death and damage to property.

## Installing the Heater

**IMPORTANT** Head of wall fixing screw must be flanged pan head type and have a diameter no less than 11mm.

No countersunk headed screws to be used for wall fixing.

The heater must be securely fixed to a wall. Screws with suitable wall fixings for solid walls are provided. If other wall types are encountered it is the installer who must choose the most suitable fixing.

### SUGGESTED FIXINGS

**SOLID BRICK/BLOCK:** No. 10 size high temperature resistant plastic inserts, 8mm drill bit. Drill hole 15mm deeper than plastic insert length.

**PLASTERBOARD** - If possible locate studding and use No. 10 woodscrews directly into the wood, otherwise M5 rawlplug intersets are suitable.



#### NOTE:

*For other wall types (e.g. timber frame and hollow concrete), seek specialist advice.*

If the floor is carpeted then the carpet should be slit and underlay cut away to allow the feet to rest firmly on the floor. Carpet gripper must be locally removed so that the feet may rest in a level position. To maintain stability, it is essential that the heater is placed on a level surface and care should be taken to avoid irregular surfaces, such as may result from carpets or tiled surrounds partially protruding under the heater.



### WARNING

The appliance must be securely fixed to the wall. The installed appliance could weigh up to 165kg and if it falls off the wall it could cause severe personal injury or death. It is the responsibility of the installer to ensure that the appropriate wall fixing is used and that the floor is capable of bearing the full weight.



This Heater is rated IPX4



**DO NOT UNDER ANY CIRCUMSTANCES ATTEMPT TO MOVE OR REPOSITION THIS HEATER WITHOUT SEEKING EXPERT ADVICE. THE HEATER SHOULD NEVER BE FREED FROM THE WALL WITH ENERGY CELLS INSIDE.**



### WARNING

To avoid the risk of fire keep all combustible materials, such as furniture, pillows, bedding, papers, clothes and curtains away from the heater - minimum clearances are shown in **Fig. 1**.



**USE CAUTION WHEN INSTALLING THIS PRODUCT, UNPAINTED METALWORK CAN HAVE SHARP EDGES.**



#### NOTE:

*ANY FIXING DROPPED INTO HEATER MUST BE RETRIEVED AS THEY MAY IMPACT PRODUCT SAFETY DURING OPERATION*



**NOTE:**

*Read these instructions carefully before proceeding any further with the installation*

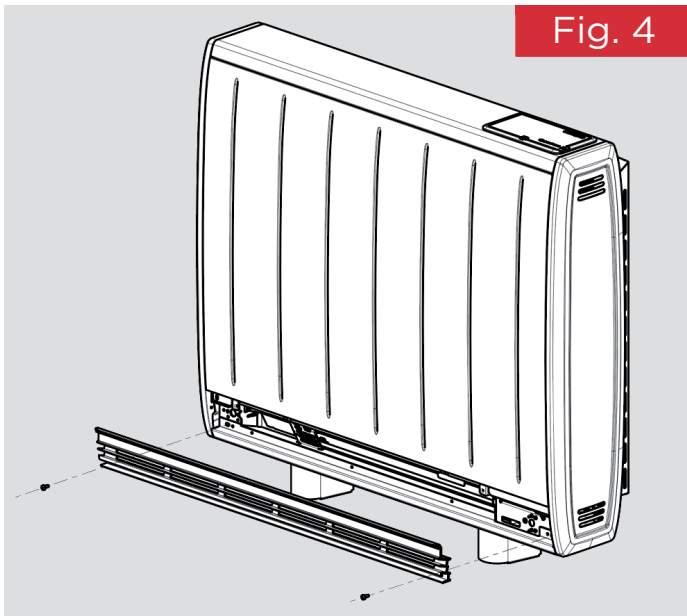

**Fig. 4**

4. Lay the heater on its back before removing the screws which hold the grille panel in position. Set the grille carefully to one side to ensure that it is not damaged.

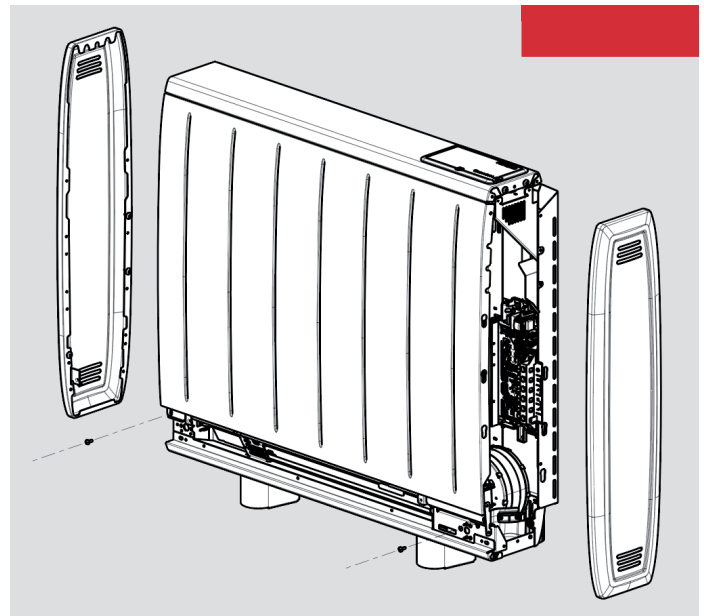

5. Remove the two screws located towards to bottom of either end of the heater, which retain the heater sides.

Push the left hand and right hand sides towards the top of the heater to release each side from its securing points.

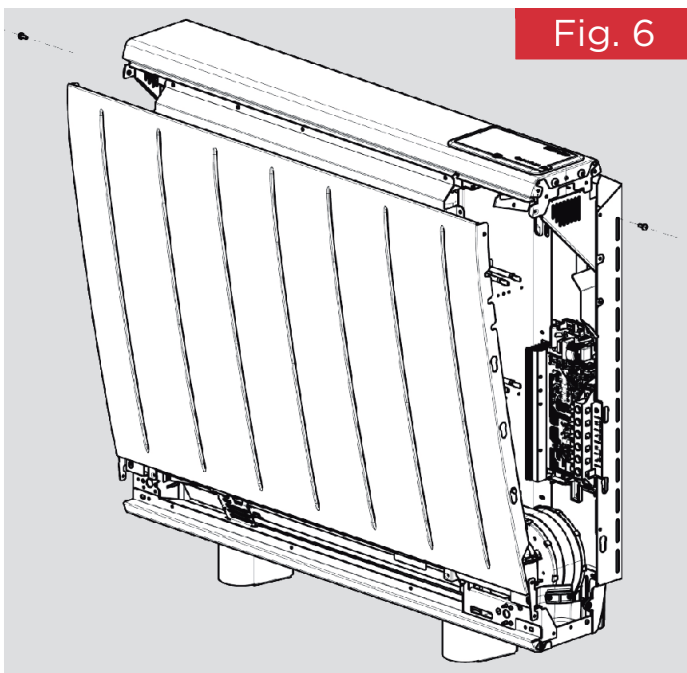

**Fig. 6**

6. Remove the two screws securing the front panel, located at the upper sides of the heater, and swing the upper edge of the front panel upwards and unhook it from along the heater base.



**NOTE:**

*Retain these screws for reassembly. If misplaced, M4 X 10 Tritap screws must be used*

- Place the heater in its final position and mark the fixing holes through the location holes visible through the back of the heater.
- Six fixing positions must be selected for ALL models QM050RF, QM070RF, QM100RF, QM125RF and QM150RF. Fig. 7.

Common fixing points for all heater sizes are shown.

Mark the positions for the fixing holes towards the bottom of each slot at the two extreme ends of the slots, this allows the heater to settle once the energy cells have been fitted. Fig. 8.

Move the heater away from the wall, drill the holes and fit the wall fixings best suited to the application.

Secure the heater to the wall using correct quantity of screws required per model, using the appropriate screw fittings.

NB: Do not fully tighten screws until energy cells are fully loaded to ensure full weight is on feet and not on the wall fixings.



**NOTE:**

*UNDER NO CIRCUMSTANCES SHOULD ANY SCREWS BE REMOVED WITHOUT FIRST REMOVING ALL ENERGY CELLS FROM THE HEATER*



**NOTE:**

*NEVER FREE THE HEATER FROM THE WALL WITH ENERGY CELLS REMAINING INSIDE THE HEATER CAVITY.*

QM050RF



QM070RF



QM100RF



QM125RF

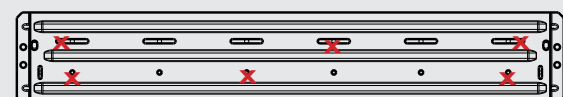

QM150RF



Fig. 7

Fig. 8

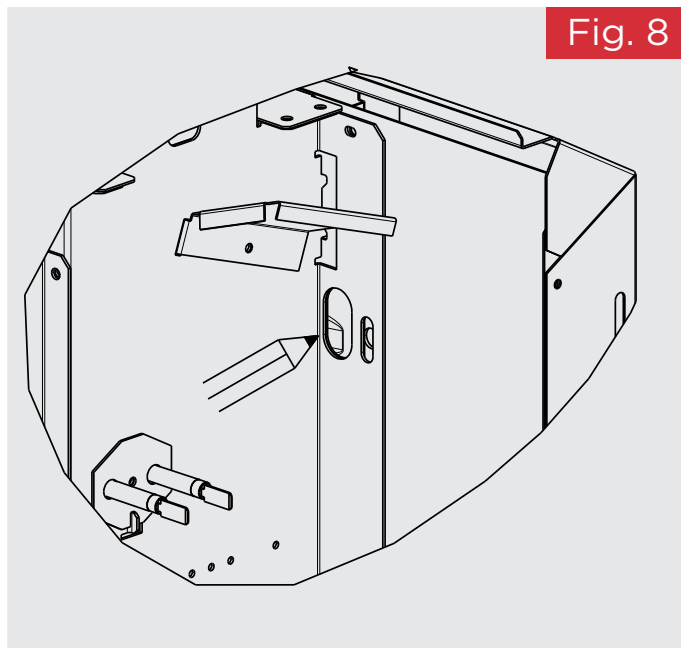

# Electrical Connections

**WARNING:** Before obtaining access to terminals, all supply circuits must be disconnected.

9. The heater leaves the factory configured to operate with two mains supplies, a 24 hour peak supply and an off peak switched supply (see Fig 9a). The heater can also be operated with a single main supply (Fig. 9b).

## Two Mains Supplies

Dual Supply - Storage / Fan circuit (Fig.9A)

Fan Circuit = PEAK L  
Storage Circuit = OFF-PEAK L

Fan Circuit = PEAK N  
Storage Circuit = OFF-PEAK N

The brown wire connected to Live

The blue wire connected to Neutral

The earth wire should be connected into the earth terminal block marked E

**WARNING:** Terminal block Minimum torque of 2Nm and Maximum torque of 2.2Nm

## Switched Supply Terminal Block

Fig. 9a

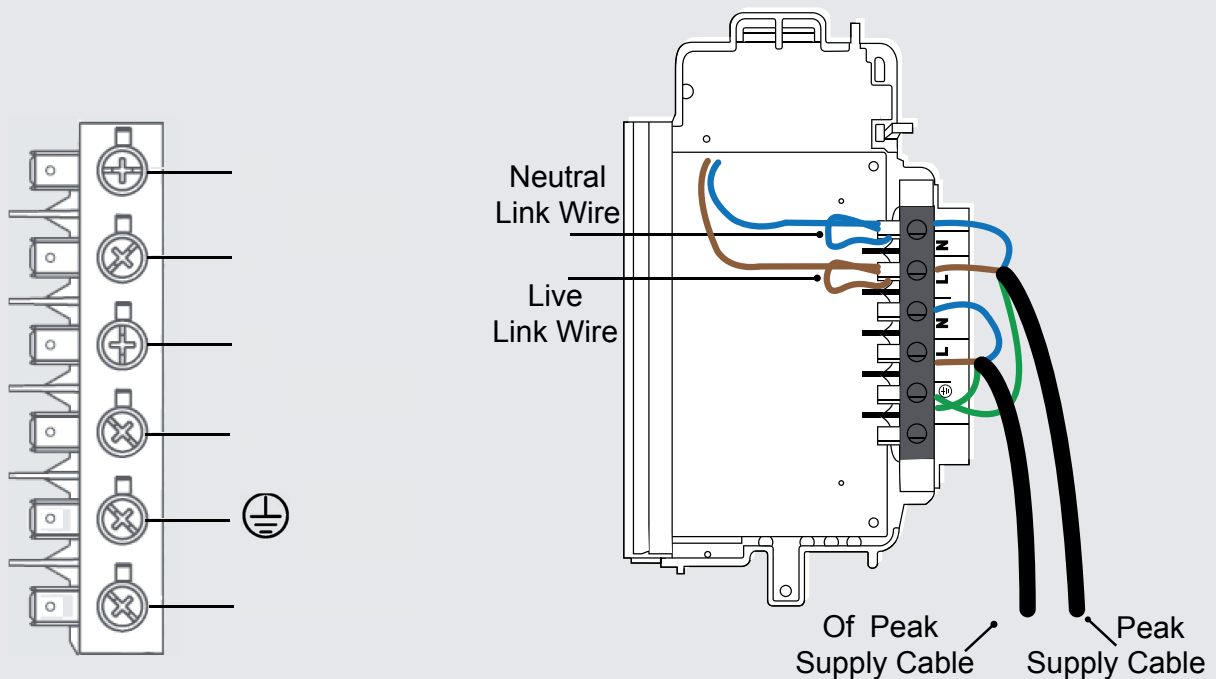

## Single Mains Supply

### Single Peak Supply requirements

Offline / Standalone Installation (not Dimplex Control connected)

**IMPORTANT** - This kind of installation relies on the property having a fixed time period, off-peak energy tariff with 'whole home switchover' whereby all wiring in the property utilises the off-peak rate when available.

The brown wire connected to Live

The blue wire connected to Neutral

#### Switched Supply Terminal Block

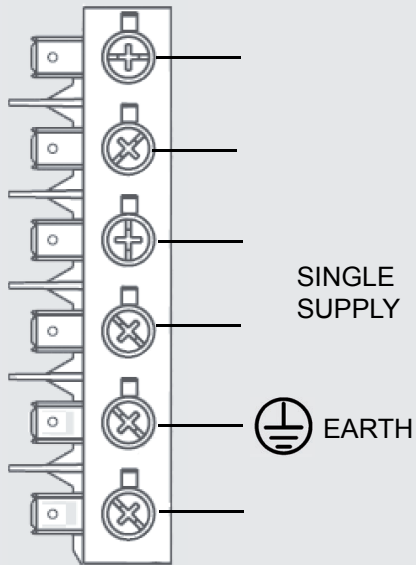

Rewire the link wires as shown in image

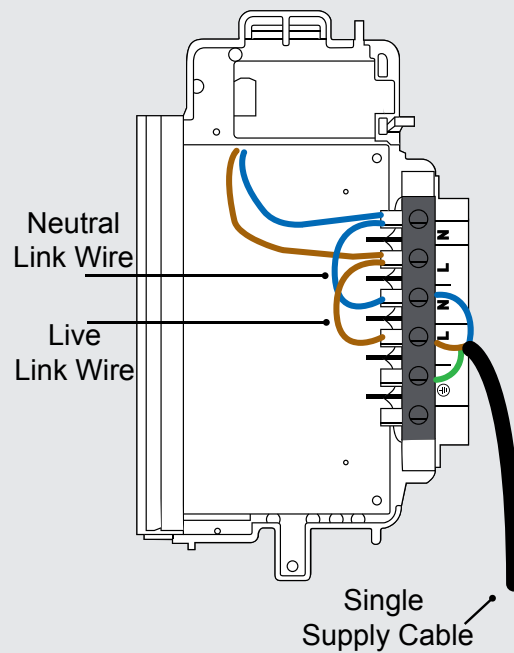

Fig. 9b



#### NOTE:

The property energy supplier should be consulted to confirm that the meter and tariff is suitable for single supply storage heating

Available fixed charge times must be manually programmed into the heater to tell it when to charge; no external timers or contactors are needed. Up-to 4 digital charge times can be set.

If charge times are not programmed into the heater, the default times will be used which are set-up by default to support dual-supply installations: 00:00 – 00:00 or 24h charge window.



A 24h charge window in a single supply installation will cause the heater to charge continuously, including times when off-peak electricity is not available, resulting in larger bills.



**NOTE:**

*As this installation relies on the accuracy of the heater's internal clock, it is good practice to check the clock annually and re-adjust if necessary. All clocks are subject to time drift and some can be up to +/- 3 sec per day*

Not all single supply meters adjust for Daylight Savings Time (DST). If DST is enabled on the heater then the digital charge times will adjust automatically. When installing with a meter that does not adjust for DST, digital charge times should be set with an hour buffer at the start and end. Most Dimplex storage heaters can fully charge within 5 hours and the automatic charge calculation may not always take a full charge so on an E7 or E10 tariff this should not cause an issue.

Smart meters may adjust for DST with server times, in which case this would not be necessary.

**Online / 'Connected' installation (Dimplex Control connected)**

**Fixed Off-Peak tariffs**

This type of installation is the same as the offline installation above, but the heater's internal clock will be synchronised with the Dimplex Control cloud server; preventing time drift and removing the need to check the heater's clock annually.

**Variable charge time tariffs**

Some energy suppliers offer variable off-peak tariffs that can work specifically with Dimplex Control supported storage heaters. In this kind of installation, digital charge times do not need to be manually programmed into the heater, the energy supplier will do this automatically via the Internet and Dimplex Control platform.



**NOTE:**

*If connectivity is lost in this set-up, the heater will automatically change back to the 'offline' or 'non-variable' charge times that the energy supplier sent to the heater during setup. The supplier should recognise that the heater is charging within fixed charging times and charge the appropriate rate. If there are any discrepancies, the energy supplier should be contacted.*



**CAUTION**

Ensure that the terminal block is not tightened on the cable insulation as this may lead to local overheating at the connection which may lead to a hazard.



**CAUTION**

The terminal block should be tightened to a minimum torque of 2Nm and a maximum torque of 2.2Nm.

The mains cable should be stripped to a length of 8mm allowing 10mm extra for cutting off/trimming. Twist the stripped cable slightly and then trim to a length of 8mm, folded over and inserted into the receptacle with no insulation trapped and likewise no conductors showing, hence why the strip length is critical. The terminal block screw should tighten down onto the formed loop and not cut through it.

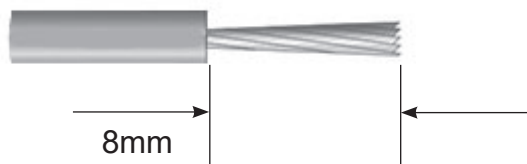

10. The mains cable entry and terminal block will be visible in the centre of the cavity at the right hand side. Insert the mains cables through the cable gland at the bottom of the heater in readiness for connection (Fig. 10).



Only heat resistant ordinary polyvinyl chloride sheathed flexible cord should be used, the following codes apply;

IEC: 60227 IEC57 or CENELEC: H05V2V2-F

Cable Sizes

Peak mains cable 1.5mm<sup>2</sup>

Off-peak mains cable 2.5mm<sup>2</sup>

Single Supply mains cable 2.5mm<sup>2</sup>



### CAUTION

If the supply cord becomes damaged, it must be replaced by a suitably qualified individual in order to avoid a hazard.

**WARNING:** Terminal Block Minimum torque of 2Nm and Maximum torque of 2.2Nm

**WARNING:** All electrical connections to the terminal block must be secure to prevent risk of ignition.



### CAUTION

If the mains connection is to be made from the left side it should be secured to the back of the heater using cable ties.

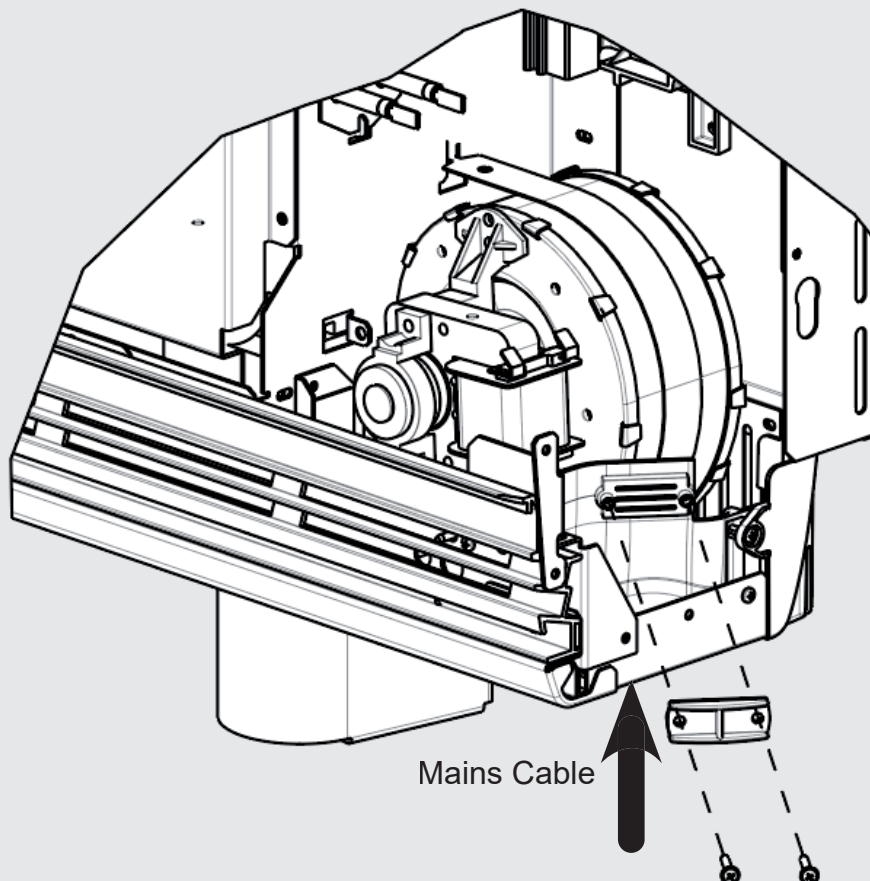

Fig. 10

Mains Cable

Fig. 11

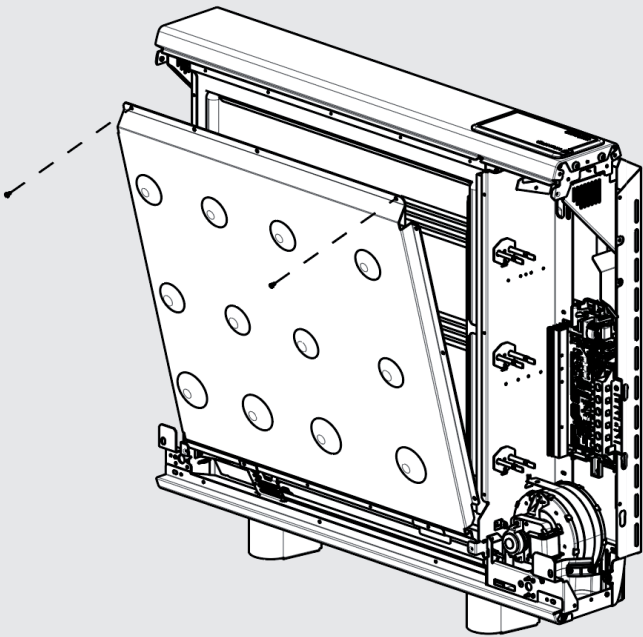

Fig. 12

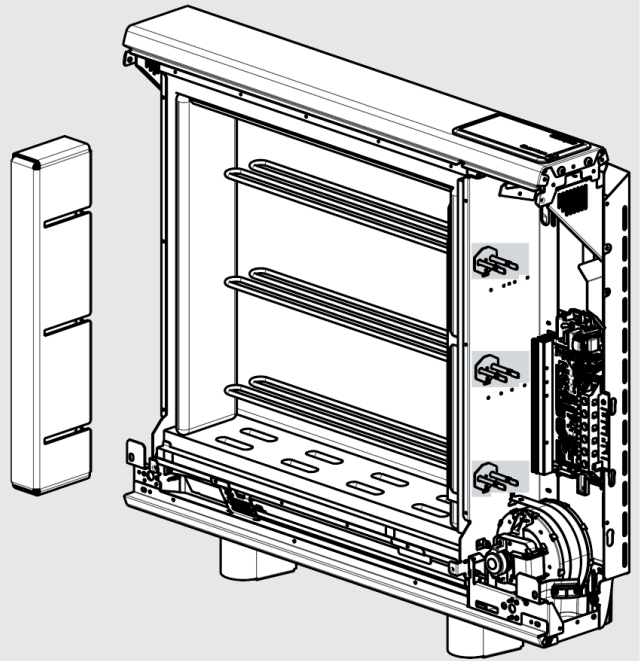

Fig. 13

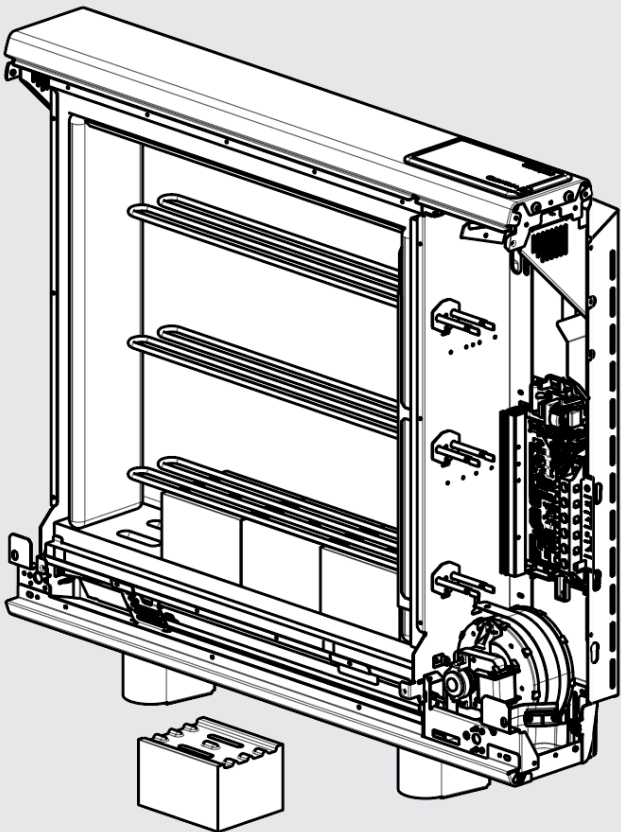
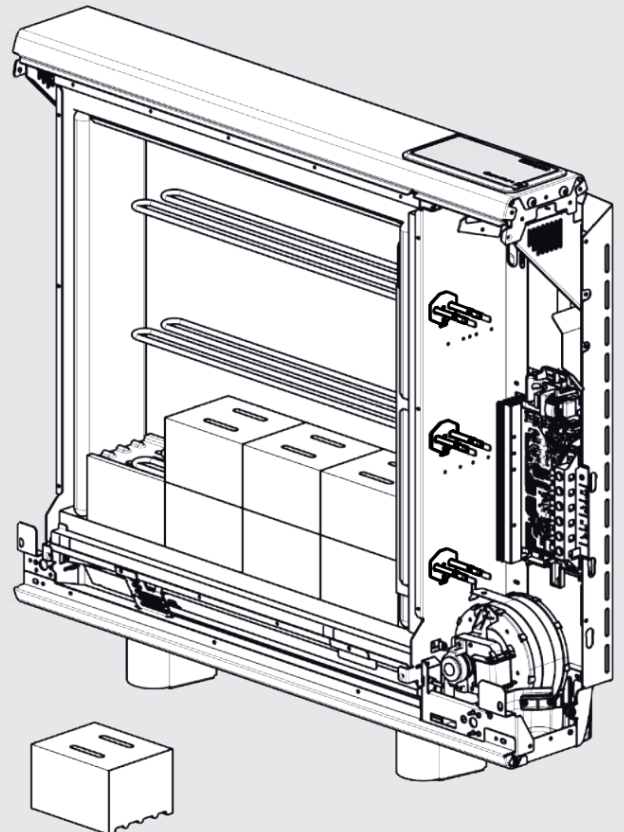

Fig. 14



## Building the Heater Core

11. Remove the inner front and insulation to gain access to the core of the heater.  
Lay the inner front carefully to one side to ensure it is not damaged. (Fig. 11)



### CAUTION

The edges of the inner front are sharp and can cause cuts to hands. Ensure the appropriate PPE is used when handling this panel.

12. Remove the cardboard element support and dispose of. (Fig. 12)



### CAUTION

The cardboard packaging is combustible and will go on fire if it is not removed.

#### Energy Cells

The energy cells are supplied separately to the heater in packs of three.  
The item code is 047243.



Energy Cells should be handled with care due to the weight and risk of personal injury.



Make sure that energy cells are kept dry. Energy cells should not be exposed to moisture and not installed if this has occurred.

13. The energy cells have several grooves on one surface for locating around the elements. The two slots through the centre of the energy cell create the air passages within the core.



Angle the element upward to fit the energy cell. Position the first energy cell of the bottom row to the right, firmly pressed against the side insulation with the element grooves facing upwards and fitting neatly around the element.

Position the second energy cell in the row against the left-hand insulation. Place the remaining energy cells between the first and second in the row. (Fig. 14)



**DO NOT DISCONNECT THE ELEMENT TERMINALS**

In addition ensure the slots for the air passages line up with the holes in the base insulation.



#### NOTE:

*The element tails must extend no further than 30mm into the right hand chamber*

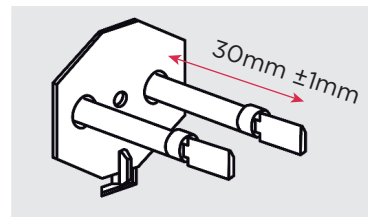

Fit the remaining energy cells to the bottom row, being careful not to damage or dislodge the element.



#### NOTE:

*The bends in the element locate around the grooves in the energy cell to secure the element.*

14. Position the second row of energy cells on top of the first but this time the energy cells must be upside down ensuring the grooves are positioned over the elements. (Fig. 14)

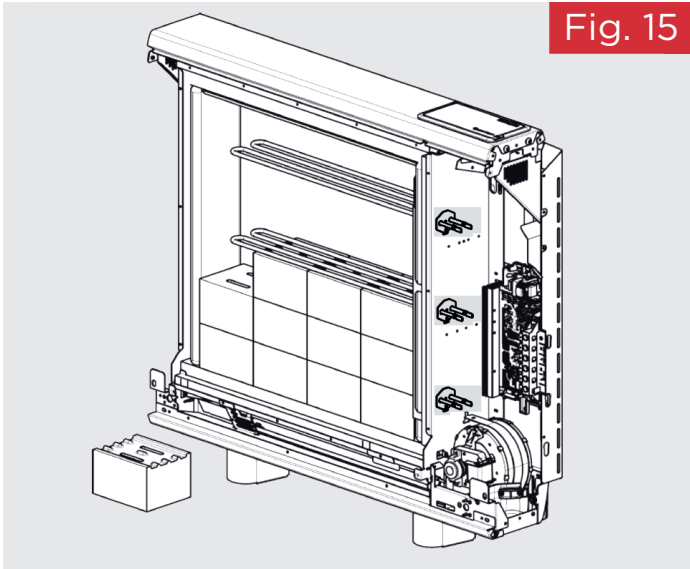

Fig. 15

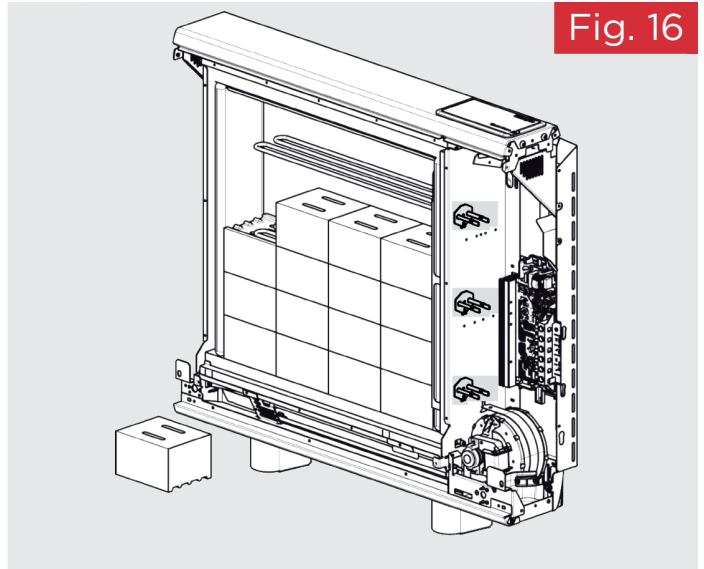

Fig. 16

15. The third row of energy cells is positioned in a manner similar to the first row. Again be careful not to damage or dislodge the element. (Fig. 15)

16. Fit the fourth row of energy cells above the third row in the upside position. Again, the first energy cell should be positioned firmly against the right-hand insulation, and the second energy cell should be positioned firmly against the left-hand insulation. (Fig. 16). Repeat for the fifth and sixth rows of energy cells built around the third element to complete the core build.

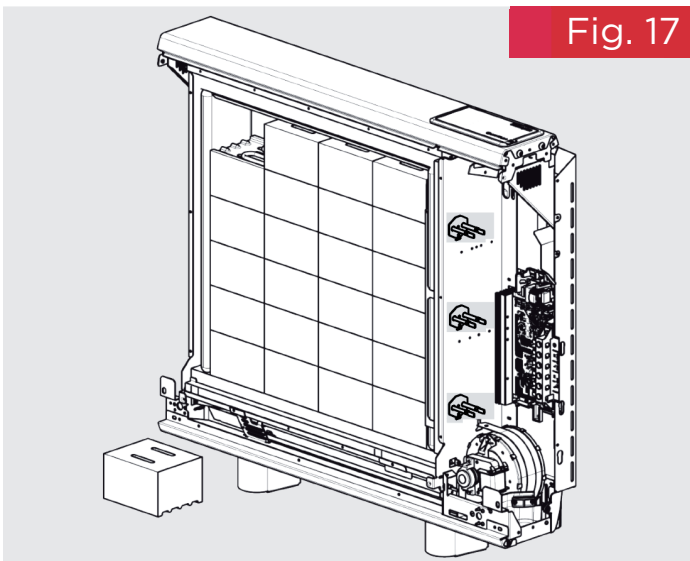

Fig. 17

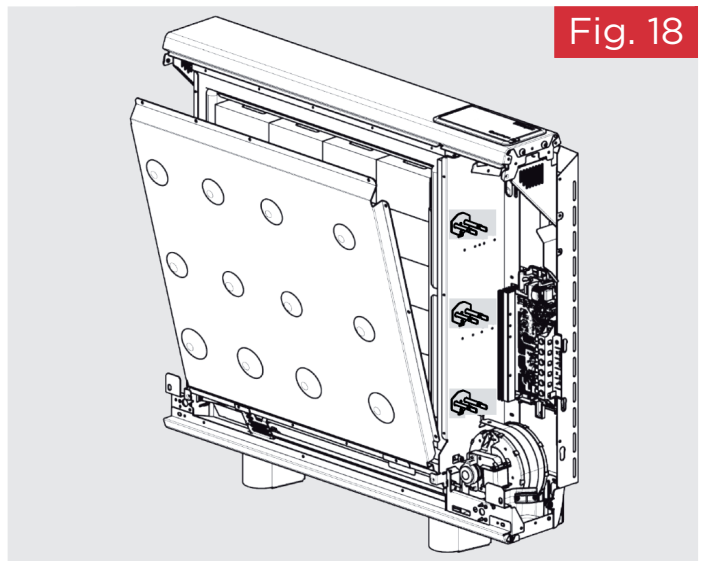

Fig. 18

17. Remember the top row of energy cells must be fitted upside down. (Fig. 17)

Check that all the energy cells are secure and evenly located.

18. Close the core by refitting the inner front panel complete with insulation, starting at position and working clockwise. (Fig. 18)

Ensure the bottom tabs are located inside the chassis and that the screws are tightly secured down each edge.

Ensure the screws retaining the heater to the wall are fully tightened, once the energy retention cells are fully loaded. (Fig. 7, page 25)

#### IMPORTANT

Double check all mains connections are secure and excess cable is restrained and not in contact with any of the heater casing.



ON NO ACCOUNT SHOULD ANY SURPLUS CABLE BE PUSHED INSIDE OR BEHIND THE HEATER.

Once installed DO NOT attempt to reposition the heater without first unloading the energy cells.

#### Reassembly

To replace the bottom grille and front panel, reverse steps Figs. 4, 5 & 6 (page 24) of these instructions under the section headed Preparation.

Ensure all fixings are secure.

# Advanced Settings

These settings can be used to significantly change the operation of the heater. While useful for very specific requirements, there is a much higher risk of User error and unintended consequences of changing these settings compared to the top-level settings menu. It is recommended that these settings are only modified by trained professionals.

To navigate to the Advanced Settings menu, from the home screen:

Press and hold **Advance** and **Menu** buttons for 5 seconds.

Each of the following headings relate to an item in the settings menu.

## Temp Settings

Temp Units (Temperature Units)

This setting defines which temperature units are displayed on the heater. The default is °C, but °F can be set. When °F is selected, the heater will convert °C values to °F and round to the nearest number.

## Charging Settings

If the output of the storage heater is not able to deliver the required heat demand throughout the day, it is possible to force the heater to store additional energy. This will manually adjust the charge calculation to store more electrical energy during the charging period.

This setting displays the available charge times for the Heater to store off-peak energy. It is presented like the Timer setup screen, but without a Target Temperature or Day Selection. This allows the Installer to set up to 4 charging On and Off times.

## Charge Times

This setting displays the available charge times for the Heater to store off-peak energy. It is presented like the Timer setup screen, but without a Target Temperature or Day Selection. This allows the Installer to set up to 4 charging On and Off times.

Default charge times (Standalone) are:

Period 1	00:00 - 00:00
Period 2	00:00 - 00:00
Period 3	00:00 - 00:00
Period 4	00:00 - 00:00

Charge times should remain at the default settings (as shown above) for twin supply installations. This setting should only be used in single supply installations. Values entered here always take precedent.

Single Supply Charge Times - below is an example of how to set the off-peak times prior to midnight.

If the off peak times is between 23:30 and 06:30 then;

Period 1	00:00 - 06:30
Period 2	07:00 - 07:00
Period 3	07:00 - 07:00
Period 4	23:30 - 23:59

## Service Settings

These items are for use by service personnel only. The settings effect the accuracy and energy usage of the heater and should only be modified by a professional.

### Room Temp (Temperature) Offset

Allows the manual adjustment of electronic room thermostat reading by +/-3.0°C

### Secondary Heater Mode

*This setting modifies the charge algorithm to prevent under-charging when enabled. If more than one heater is installed in the same room, it is recommended that the smallest capacity heater(s) is set as a Secondary. This is disabled by default.*

## Heat Source Setting

With this setting, it is possible to restrict use of peak rate energy for each of the following modes:

- Timer Mode
- Boost Mode
- Setback Mode



### NOTE:

*Increased use of peak rate electricity could lead to increased running costs*

## Factory Reset

This setting allows the User to restore the default values to all settings. Returning the product to the same state that it left the factory.

# Settings

To navigate to the Settings Menu, from the Home Screen:

Press the **Menu** button to access the Main Menu. Rotate the **Dial** to highlight 'Settings', then press the **Dial**. Each of the following headings relate to an item in the Settings Menu.

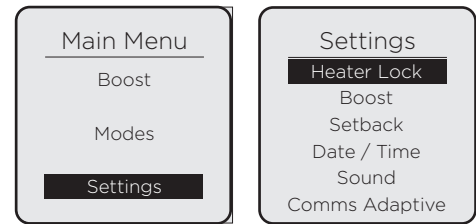

## Heater Lock

### Set Lock

Heater (PIN) Lock can be enabled here by highlighting 'Heater Lock' and pressing the **Dial** to enter the Heater Lock menu. Highlight 'Set Lock', press the **Dial**, enter a 4-digit PIN code, then pressing the **Dial** to lock the heater.

### Lock Settings

Before PIN Lock is enabled, the User can select 'Lock Settings' to enable/disable the Advance and/or Boost functions, as well as enable/disable modification of the Boost Temperature and Boost Duration. See below.

### Boost Lock

Three settings can be modified within this Menu:

- **Enable / Disable** - The 'Boost' Menu Item can be Enabled/Disabled while PIN Lock is active.
- **Temperature Rule** - Modifiable Boost Temperature while PIN Lock is active
  - **Enable** - While Boost is active, the User can modify this value as they normally would
  - **Disable** - Default value will be loaded. When the user tries to modify the value, the UI will show the following text: 'Disabled'.
- **Duration Rule** - Modifiable Boost Duration while PIN Lock is active.
  - **Enable** - While Boost is active, the User can modify this value as they normally would
  - **Disable** - Default value will be loaded. When the user tries to modify the value, the UI will show the following text: 'Disabled'

### Advance Lock

- **Enable / Disable** - This setting allows the User to Enable or Disable the **Advance** button while PIN Lock is active.



# Circuit Diagram - QM RF Series G.9

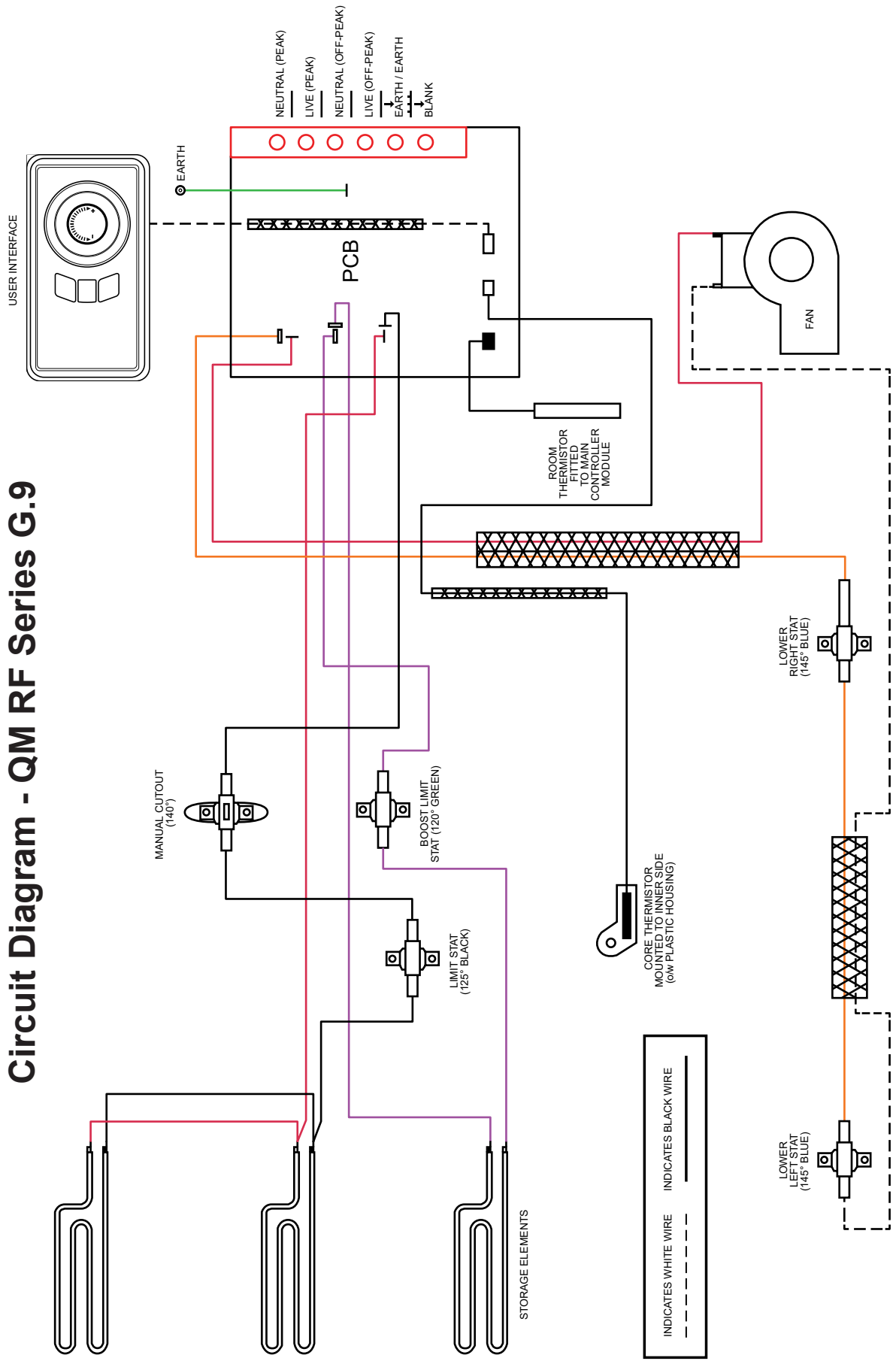

# Quantum G.9 Commissioning Checklist

**Note:** This represents the minimum software setup to commission this heater. Instructions here do not substitute or replace installation instruction requirements or warnings in the rest of this manual.

Model No.		Serial No.		Series		Install Date	
-----------	--	------------	--	--------	--	--------------	--

✓ each box to complete

- |  |  |
|--|--|
| 1. Casing condition good, no dents or scratches. | 2. 240V AC power available to both Peak and Off-Peak circuits. |
|--|--|

3. For Single Supply installations, set the heater Standalone Charge Times according to End User electricity tariff's Off-Peak rate times.
- A. Enter '**Advance Setup**': Press and hold **Advance/Menu** buttons at the same time for 5 seconds.
  - B. Select '**Charging**' menu.
  - C. Select '**Charge Times**' sub-menu
  - D. Factory default times are 00:00 - 00:00. In this case the heater takes the charge whenever the Off-Peak supply available and the Run time been calculated.
  - E. Set the Charge Times according to End User electricity tariff's Off-Peak rate times.

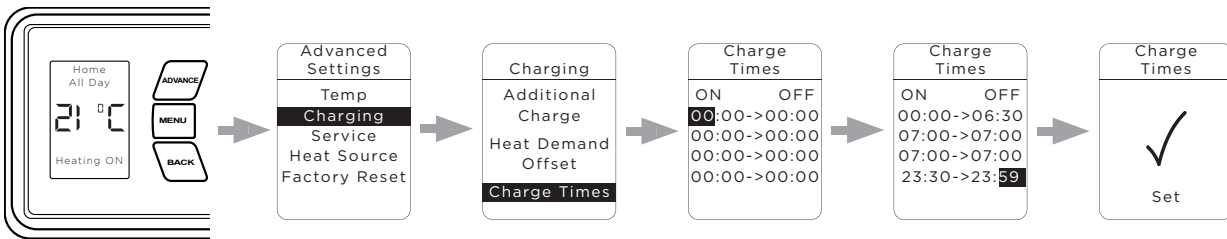

4. Check date and time is correct. Set Daylight savings time if appropriate (see wiring section)

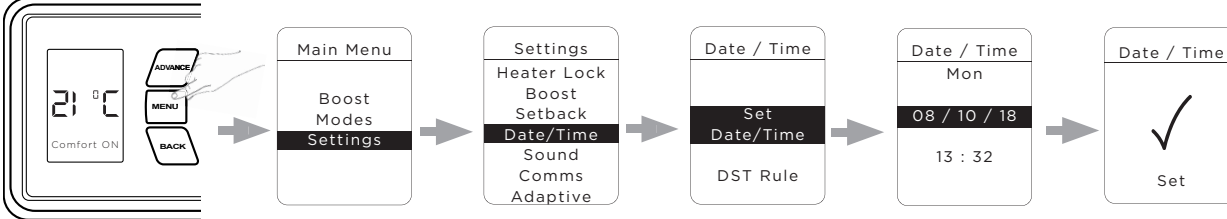

5. Select Timer Mode (as per customer requirements).

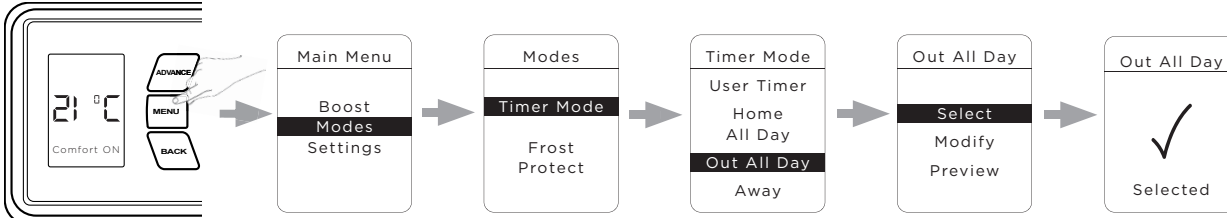

6. Set Comfort Times (as per customer requirements).

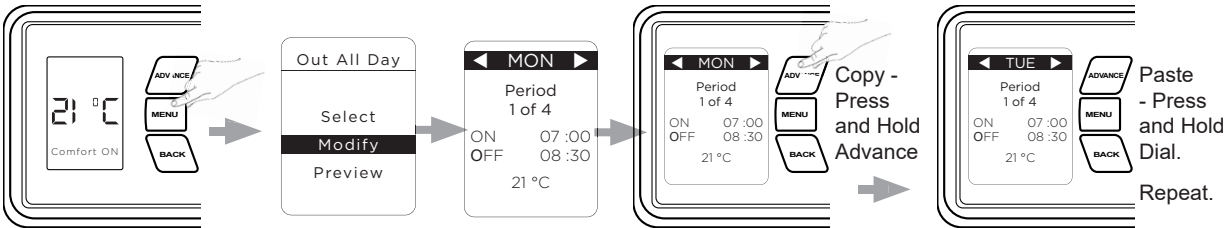

7. Fan and Boost Test  
(NOTE - DISABLE BOOST WHEN TEST IS FINISHED).

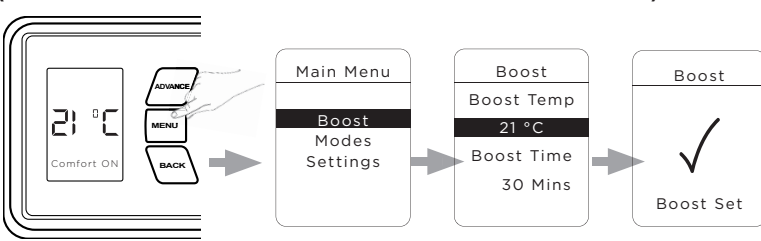

# Battery Replacement



## NOTE:

*Battery should be disposed of in an appropriate manner*

**IMPORTANT:** Before replacing the battery ensure the heater is isolated from the electricity supply.

This product is fitted with a replaceable battery in the controls. To replace the battery, follow the steps below:

1. Push a small flat headed screwdriver into the opening on the right hand side of the User Interface (Fig. 19) to release the clip.
2. Lift the User Interface module out away from the heater being careful not to damage the cable
3. Unscrew the battery cover (Fig. 20) to gain access to the battery holder.
4. Use a small flat headed screwdriver to remove the battery from the battery holder and replace the battery.
5. Replace the battery access cover.
6. Push the User Interface module back into place, again avoiding damage to the cable.

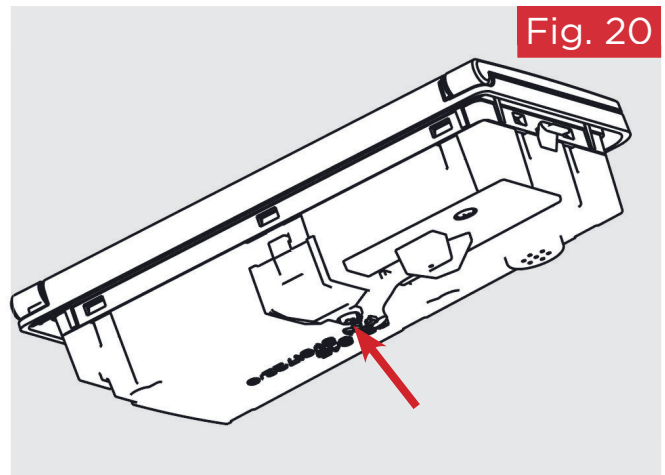
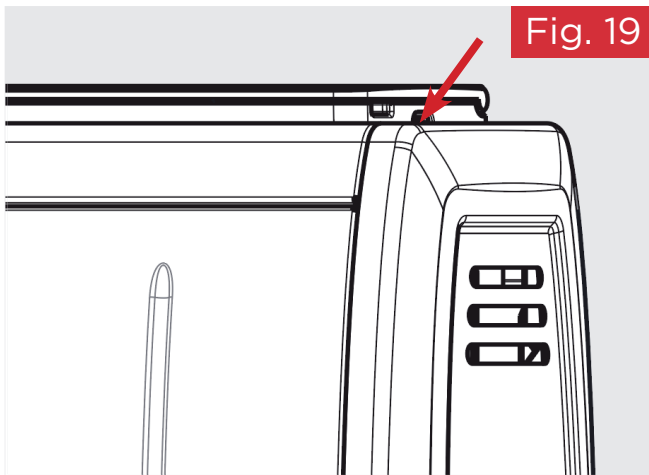

## Important

During the initial operation, some odour may be noticed due to the newness of materials used in manufacture. This is normal and will disappear after a short period of use. It is however advisable to keep the room well ventilated

## Cleaning

**WARNING - ALWAYS DISCONNECT FROM THE POWER SUPPLY BEFORE CLEANING THE HEATER.**

Before commencing cleaning, isolate the heater from the electrical supply and allow it to cool. The outside can be cleaned by wiping it over with a soft dry cloth. Do not use abrasive cleaning powders or furniture polish, as this can damage the surface finish.



### Important

For electrical products sold within the European Community. At the end of the electrical products useful life it should not be disposed of with household waste. Please recycle where facilities exist. Check with a Local Authority or retailer for recycling advice in your country. Batteries should be disposed of or recycled in accordance with WEEE Directive 2012/19/EU. Packaging should be recycled where possible.

## Your Guarantee



To view the full guarantee terms and conditions scan this QR code using your smartphone or go to <https://www.gdhv.co.uk/guarantee-terms-and-conditions>.

Your Product is manufactured by Glen Dimplex UK operating as Glen Dimplex Heating & Ventilation. GDHV designs and manufactures products to ensure they deliver reliable service for normal use in domestic dwellings and, where specified by us, in light commercial premises. GDHV products are individually tested before leaving the factory, Your product comes with a 2 year parts and labour guarantee for repair or replacement of faulty goods and/or partial refund in the event that a repair or replacement is not available.

Your guarantee is provided by Glen Dimplex UK Ltd operating as Glen Dimplex Heating & Ventilation Ltd, Millbrook House, Grange Drive, Southampton SO30 2DF. Terms and conditions apply.

The GDHV guarantee does not in any way diminish or affect your statutory consumer rights in connection with your product.

If you experience a problem with your product during or after the guarantee period, visit our online help centre:

<https://www.dimplex.co.uk/gdhv-help-centre>

If you cannot solve your issue online, contact the customer care team on 0344 879 3588

Please note that when you contact us you will need to provide the model and serial number of your product and a description of the fault which has occurred.

## Register



**IMPORTANT:** Please register your product without delay.

Simply scan this QR code using your smartphone, or go to

<https://www.dimplex.co.uk/register>.

If you do not have access to the internet, please call us on 0344 879 3588

## Why Register Your Products With Us?



### Faster Customer Service

Once you have registered your product, our customer service team will be able to quickly access your details when you contact us, allowing them to help you sooner.



### Guarantee Management

Upon registration, you will receive a confirmation email including a summary of your product guarantee, a copy of our terms and conditions and a copy of your proof of purchase (optional).



### Product Recall Notification

If your product is registered you will automatically be contacted with applicable safety notifications, or in the unlikely event of a product recall.

Please register your product with us within 28 days of date of purchase to enable us to provide efficient customer service if you need to contact us, to contact you in the event of a product or safety update, to extend your guarantee where applicable, and, if you choose, to send you additional information about our products and services.

Register your product at <https://www.gdhv.co.uk/register>, or if you do not have access to the internet, call us on 0344 879 3588.

On registering you will automatically receive a copy of the terms and conditions of your guarantee, which can also be downloaded at any time from <https://www.gdhv.co.uk/guarantee-terms-and-conditions>. If you do not have access to the internet, call us on 0344 879 3588 and we will send them to you by post.

Products within the Quantum range are protected by one or more of the following patents:

Great Britain: GB2481048, GB2487147, GB2487148, GB2487781, GB2500736, GB2511538, GB2526552

International: EP2830832, EP2831688, EP2965166, EP3132324, WO2011154521, WO2013144170, WO2014135667, WO2015181136



**Customer Helpline:** 0344 879 3588  
[gdhv.customersupport@glendimplex.com](mailto:gdhv.customersupport@glendimplex.com)  
[www.dimplex.co.uk](http://www.dimplex.co.uk)

Glen Dimplex Heating and Ventilation  
Millbrook House, Grange Drive, Hedge End, Southampton, SO30 2DF  
Glen Dimplex Europe, Airport Road, Cloghran, Co. Dublin K67 VE08



© Glen Dimplex. All rights reserved. Material contained in this publication may not be reproduced in whole or in part, without prior permission in writing of Glen Dimplex.